

New connection services charging arrangements

2024-2025



Wessex Water
YTL GROUP

FOR YOU. FOR LIFE.

Executive summary

These charging arrangements set out, in a single document, our charges relating to new connection services. This document is available on our website, but we are happy to provide you with a copy on request.

To request a copy, please either:

Email: developer.services@wessexwater.co.uk

Telephone: 01225 526 222 or 01225 526 333

Write to: Developer Services
Wessex Water
Claverton Down
Bath, BA2 7WW

Alongside this document, we also provide an excel calculator to aid our customers to assess the likely charges they will incur.

Wessex Water has an obligation to publish its range of charges each year of which there a number of documents. All of these documents can be found on our website. This document fits in with the Company's charges publications per Figure 1 below.

Figure 0-1: Charges publication documents

<u>Wholesale charges</u>	<u>Household charges</u>	<u>Bulk charges for NAVs</u>	<u>New connection services charges</u>
Wholesale charges scheme	Household charges scheme	Bulk charges for NAVs scheme	New connection services charges scheme
Wholesale Charges Board assurance statement	Household Charges Scheme Board assurance statement	Bulk Charges for NAVs Board assurance statement	New connection services charges Board assurance statement
	Household charges statement of significant changes	Bulk Charges for NAVs calculator	New connection services charges calculator
			New connection services charges worked examples

Contents

Executive summary	2
Contents	3
1. Introduction	5
1.1 Our business	5
1.2 Scope of our charging arrangements.....	5
1.3 Payment.....	6
1.4 VAT	6
1.5 Complaints and disputes relating to standards of services	6
1.6 Frequently asked questions.....	8
2. Our charging arrangements – an overview	9
2.1 What will you need to pay to connect to our network?	9
2.2 Income offset.....	16
2.3 Transitional arrangements.....	17
2.4 Validity of Quotations	19
2.5 Statement of Significant Changes	20
2.6 Further information	27
2.7 Frequently asked questions.....	27
3. Applying for a new connection	28
3.1 Connecting your property to our network.....	28
3.2 How do you apply for a new connection?	28
3.3 How do you find out about our mains and sewers?	28
3.4 Abortive and additional visits	30
3.5 Working in the Road.....	30
4. New water supply connections (s45)	32
4.1 Do you need to connect to our supply network?	32
4.2 Who can connect your property to our water supply network?.....	32
4.3 Our charges – connecting to our water supply network	33
4.4 Disconnection charges	35
4.5 Frequently asked questions.....	35
5. Water mains requisitions (s41), adoptions (s51) and diversions (s185)	36
5.1 Do you need to lay (or divert) a new mains?.....	36
5.2 Who can lay (or divert) new mains and make the connections?	36
5.3 Our charges – laying (or diverting) a new mains.....	37
5.4 New appointments and variations (NAVs)	39
5.5 Our charges – adoption of assets.....	39
5.6 Our charges – diversion of existing mains	40
6. New sewer connections (s106/s107)	41
6.1 Do you need to connect to our sewer network?	41
6.2 Who can connect your property to our sewer network?	41
6.3 Our charges – connecting to our sewer network.....	41
6.4 Frequently asked questions.....	42
7. Sewer requisitions (s98), adoptions (s102/s104) and diversions (s185)	43

7.1	Do you need to lay (or divert) a new public sewer?	43
7.2	Who can lay (or divert) a new public sewer?	43
7.3	Our charges – laying (or diverting) a new public sewer	44
7.4	New appointments and variations (NAVs)	45
7.5	Our charges – adoption of assets.....	46
7.6	Surety or deposit payments.....	48
7.7	Our charges – diversion of existing sewers	49
8.	Water and sewerage infrastructure charges (s146)	51
8.1	What is an infrastructure charge?.....	51
8.2	Do you need to pay an infrastructure charge?.....	51
8.3	What work is required?.....	51
8.4	Our charges – network reinforcement.....	51
8.5	What is the income offset?	53
8.6	What charges are payable?.....	53
8.7	Upsizing new assets for future use.....	56
8.8	Network enhancement	56
8.9	Interaction with the planning system.....	57
8.10	Frequently asked questions.....	57
9.	Our contact details	58
10.	Our charges in full.....	59
	Appendix A Glossary and defined common terms.....	69
	Appendix B Prescribed Worked Examples	77

1. Introduction

1.1 Our business

We supply water and sewerage services in an area with a population of over 2.8 million customers, covering around 10,000 km².

Figure 1-1: Our business

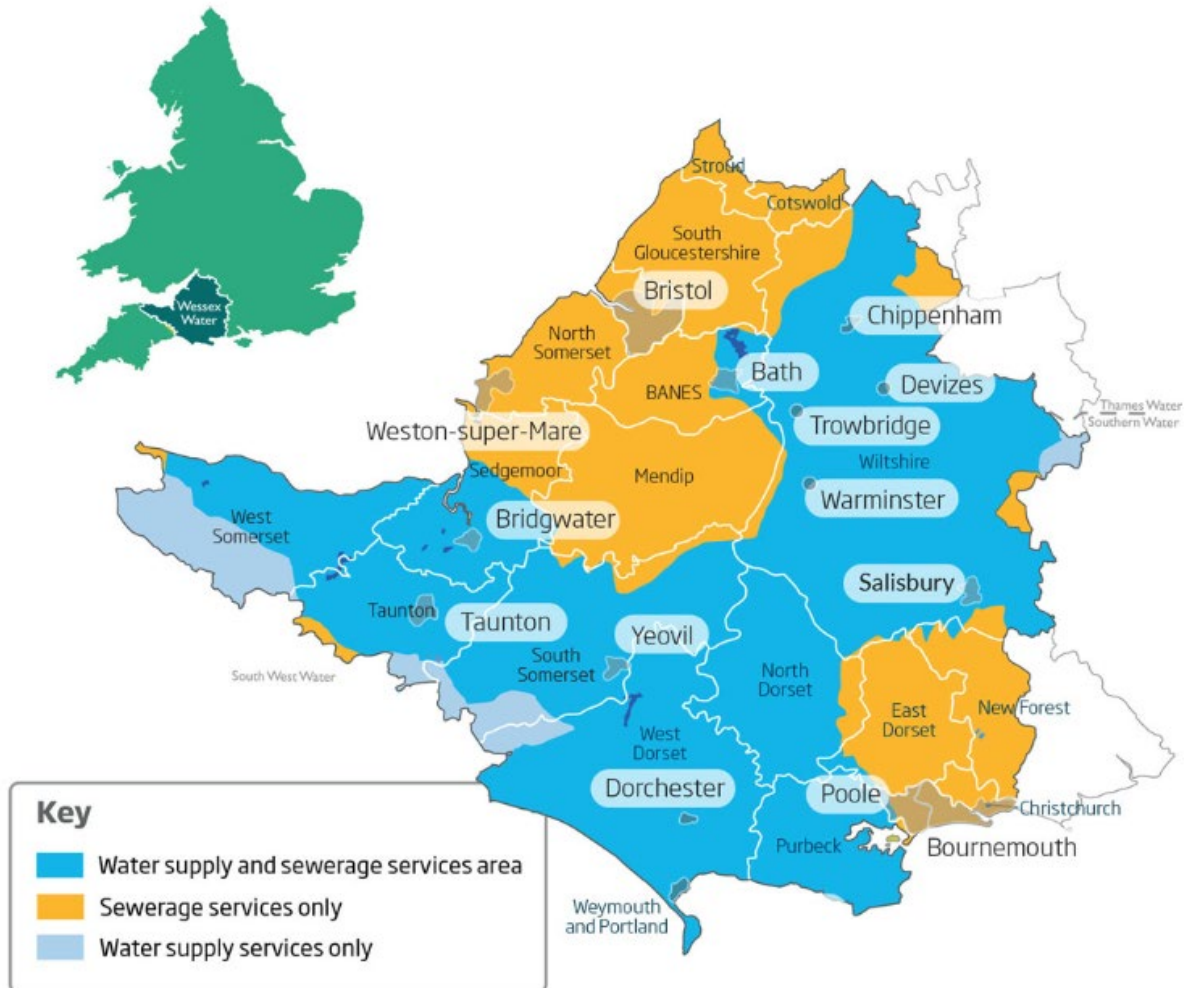

Historically, we installed all the pipes required to supply new housing developments with water and sewerage services. While we still need to undertake some work to ensure new connections are safe and meet certain industry standards, customers can now choose who connects their new development to our water and sewerage networks. Water Supply Licensees (retailers for businesses) can also request that we provide new connection services on behalf of their customers.

1.2 Scope of our charging arrangements

These charging arrangements fix charges for services provided to those developing land and laying new water and sewerage infrastructure for residential and commercial purposes. Water, sewerage and trade effluent primary and non-primary charges to residential and commercial premises are fixed under separate charges schemes. These charging

arrangements set out in a single document our charges for the charging year (from 1 April 2024 until 31 March 2025). These charging arrangements replace all earlier versions.

1.3 Payment

Payment is on request, as per the standard payment terms detailed on the invoice, quote or offer letter. Please see the guidance notes for each activity.

1.4 VAT

All charges shown throughout this document are exclusive of Value Added Tax (VAT). We will add VAT, if applicable, at the appropriate rate to our charges.

The VAT rules are complex and primarily depend on the nature of the work undertaken and the type of property concerned. It is therefore not possible for us to set out the VAT liability for each item. Certain items included in this document will be treated as outside the scope of VAT, charged at either 0%, a reduced rate (currently 5%) or a standard rate of VAT (currently 20%).

For example, if you are constructing a new housing estate and require us to install a new water main that will be used solely to connect new dwellings, our charges will be zero rated for VAT purposes. In contrast, our charges to install a new water main connecting existing or commercial properties will be subject to VAT at the standard rate (currently 20%). Should the work be carried out as part of a property renovation or conversion for residential use, then VAT is likely to be charged at the reduced rate (currently 5%). Please contact us should you require further information.

1.5 Complaints and disputes relating to standards of services

If you feel we have not met the standards of service you would expect, you can contact us in the following ways.

Email: developer.services@wessexwater.co.uk

Telephone: 01225 526 222 or 01225 526 333.
Monday to Thursday, 8.30am to 4.30pm, Friday 8.30am to 4pm.
To protect our customers and staff calls may be recorded.

Write to: Developer Services
Wessex Water
Claverton Down
Bath, BA2 7WW

1.5.1 Escalation of your complaint

We hope we can resolve your complaint without the need for it to be escalated. We recognise, however, that you might not be happy with the way that we have resolved your complaint or the time taken to resolve it. If you are unhappy with our response, you can write to our Managing Director at the address given above.

1.5.2 Disputes relating to self-lay agreements

If your complaint relates to a self-lay agreement, you should direct your dispute in the first instance to our Head of Developer Services at the above address. If a resolution is not forthcoming, and with the agreement of both parties, the dispute should be referred to mediation in accordance with the Centre for Effective Dispute Resolution (CEDR) Model Mediation Procedure.

If the parties do not agree to mediation, the dispute shall be referred to the decision of a single arbitrator mutually agreed upon or, failing such agreement, to be appointed by the president of the Chartered Institute of Arbitrators.

1.5.3 Complaints to Ofwat

You may, however, want to complain to Ofwat about the service or charges you have received from us, or if you feel that we are in breach of the Water Industry Act 1991 or the Competition Act 1998. Ofwat's address is given below.

Ofwat
Centre City Tower
7 Hill Street
Birmingham, B5 4UA
www.ofwat.gov.uk

1.5.4 Role of CCW

The Consumer Council for Water (CCW) is the representative for water and sewerage customers in England and Wales. It operates the Water Redress Scheme (WATRS) that covers some complaints about the connection charges regime.

CCW can consider complaints concerning administration, policies or process, as well as answer queries and provide advice about the connection charges regime. If a customer remains unhappy, they are able to refer their complaints to WATRS.

1.6 Frequently asked questions

Table 1-1: Frequently asked questions

Question	Response
Can I get a paper copy of this document	You can download a copy of this document from our website or request one by phoning us on 01225 526 222 or 01225 526 333 or emailing us at developer.services@wessexwater.co.uk
Why are you setting new charges?	Changes introduced by the Water Act 2014 enabled Ofwat to develop a new rules-based charging framework. This is intended to ensure that charges comply with overarching principles of fairness and predictability and are more customer focused.
When do the new charges take effect?	From 1 April 2024 for developments started after this date.
What if I've already started work?	Section 2.3 of this document sets out the transitional arrangements that will apply for projects started before 1 April 2024.
How do I make a complaint?	We hope you will not have reason to make a complaint, but if you do, section 1.5 sets out our procedures for handling complaints and disputes.
How do I know what work is required?	This document sets out our Charging Arrangements and should be read in conjunction with our technical guidance documents, which set out more information about the works required and industry standards.

2. Our charging arrangements – an overview

2.1 What will you need to pay to connect to our network?

Each development will have its own requirements and the cost to connect to our network will vary by site. With this in mind, we have set out our charges in a way that allows you to estimate what services you require and what costs you need to pay.

The simplest development might mean a single connection to our water mains: this would mean that you would pay only a water connection charge and an infrastructure charge, which is your contribution towards the network reinforcement required to ensure we continue to deliver excellent services to all customers. The most complex development might require a large number of properties to be connected to new water mains and new public sewers: a customer would therefore need to pay connection charges (water and sewerage), infrastructure charges (water and sewerage) and, if we were carrying out the work, requisition charges (water and sewerage).

Each of the services we offer are set out in this document, in the following sections.

Table 2-1: Services that you might require (and where to find them)

Service requirements	
Section 3	Applying for a new connection
Section 4	New mains connections (water)
Section 5	Mains requisitions, adoptions or diversions (water)
Section 6	New sewer connections (sewerage)
Section 7	Sewer requisitions, adoptions or diversions (sewerage)
Section 8	Infrastructure charges (water and sewerage)

2.1.1 Non-contestable and contestable works

Each of the tables sets out our charge for undertaking the service provided.

- Some work needs to be undertaken by us: it is non-contestable and we need to undertake this work to meet our statutory obligations – you cannot let anyone else do this work for you.
- Other work is contestable: this is work that you can get someone else to do. Our charges set out the price we would charge if we were to complete that work.

We have made clear in this document which work is non-contestable and which is contestable. For contestable aspects, you can ask us to undertake all the work required, or you can obtain estimates from other providers for the work required. So long as you know what services you require, the tables will help you understand what charges you will incur in making the connection to your new development. You will need to estimate what works you require and we will need to review this before we can confirm what your final charges will be. Your charges based on the scope of the work defined at the time of the quotation shall remain fixed for the duration of the quotation we provide to you. However where the scope of work changes due

to a change in your requirements or obligation or constraints by third parties we reserve the right to recalculate your charges based on the change in scope required.

We have created a spreadsheet calculator displaying our fixed up-front costs to aid estimation of the total charges payable, available on our website.

We recognise that you may need help understanding what works you require. We are happy to help and can arrange a site visit so that we can assess what you need to make the connection to your new development.

2.1.2 How have these charges been calculated?

Changes introduced by the Water Act 2014 have allowed Ofwat to move away from the legislative charging framework to a more flexible charging rules-based framework. Ofwat's rules reflect guidance from Defra, which set out five overarching objectives, being:

- stable and predictable charges;
- transparent and customer-focused charging;
- fairness and affordability;
- environmental protection; and
- cost reflective of the relevant service.

We have developed charges that, we believe, are customer-focused. They comply with the requirements of Ofwat's rules and we have endeavoured to make them more transparent so that customers are clear what they are actually paying for and where they can choose an alternative provider.

We developed our charges following customer research, engagement and consultation. We also asked economic consultants to review these charging arrangements and the underlying models to ensure that we are compliant with Ofwat's rules and consistent with competition law. Our technical auditor has reviewed the data and methodologies used to set our charges.

Our charges are set to recover costs that we reasonably incur. The charges we set are based on assessments of labour, plant and materials required to complete each activity, using times and costs from observed data.

2.1.3 Non-household customers

Since April 2017, businesses and other commercial customers have been able to choose their water and sewerage retailer. If you are a business, you can request any of the activities contained in this document from your retailer. Alternatively, you can contact us directly to carry out the work or contact a self-lay provider to complete the work on your behalf.

These charging arrangements are only applicable in respect of the provision of services to household and non-household premises using water for domestic purposes only.

Where such premises require additional flows for non domestic purposes the charges for providing the additional services shall be charged on a site specific bespoke basis.

Water for domestic purposes refers to water used at the premises for drinking, washing, cooking, central heating and sanitary purposes as defined in section 218 of the Water Industry Act 1991.

2.1.4 What will I actually need to pay?

You only need to pay for the services that you choose to procure from us, or that only we can provide. Some development sites will require additional services, for example provision of hydrants (covered in our Wholesale Charges) or where there are environmental concerns and regulations to overcome. These costs will vary by site and circumstance and are not included in these charging arrangements: we will charge for these on the basis of costs actually incurred.

2.1.5 Connecting to our water and sewerage networks

Figure 2-1 and Figure 2-2 show, schematically, where each of the charges might apply.

- Connection charges¹ are payable for on-site works to connect new properties to our network (within the dark green area).
- Requisition charges¹ are payable for works to build new mains or sewers required to support new development.
- Infrastructure charges are payable for network reinforcement required as a result of new development (within the light green area).

Works required within the pink area are not linked to new development and new connection services' customers are not required to pay for these.

¹ A large amount of this work is contestible and there are other providers available for these services.

Figure 2-1 The water network

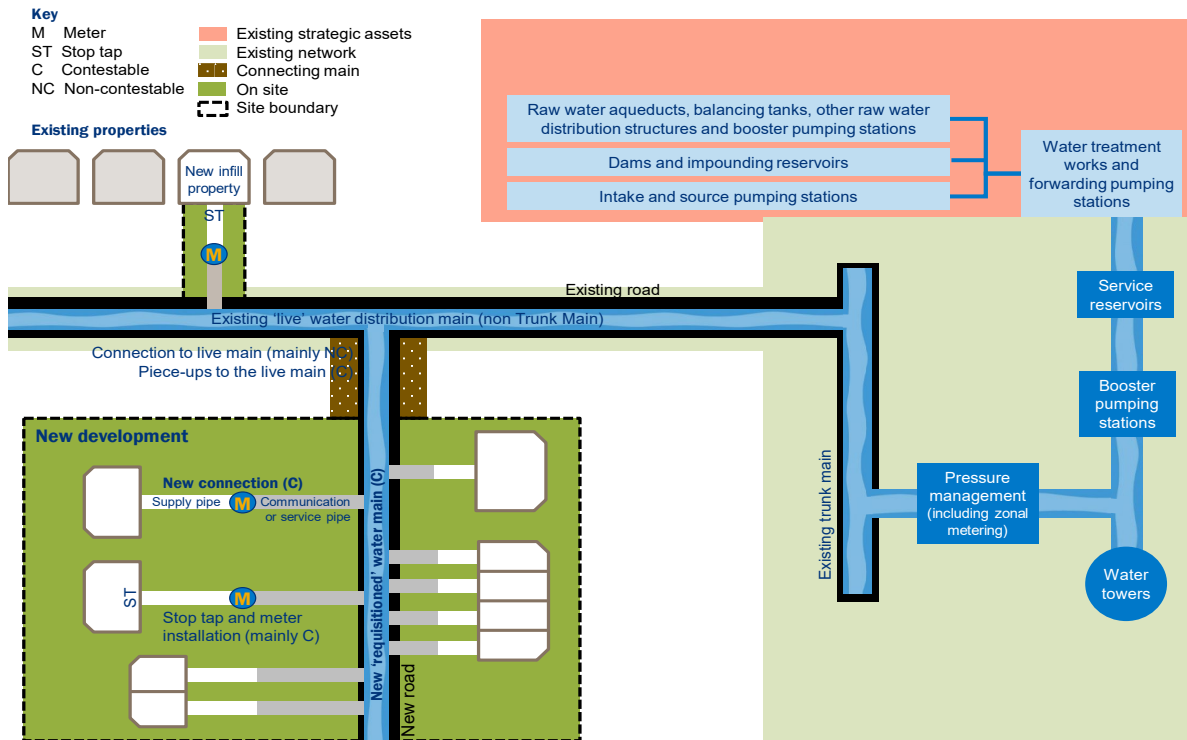
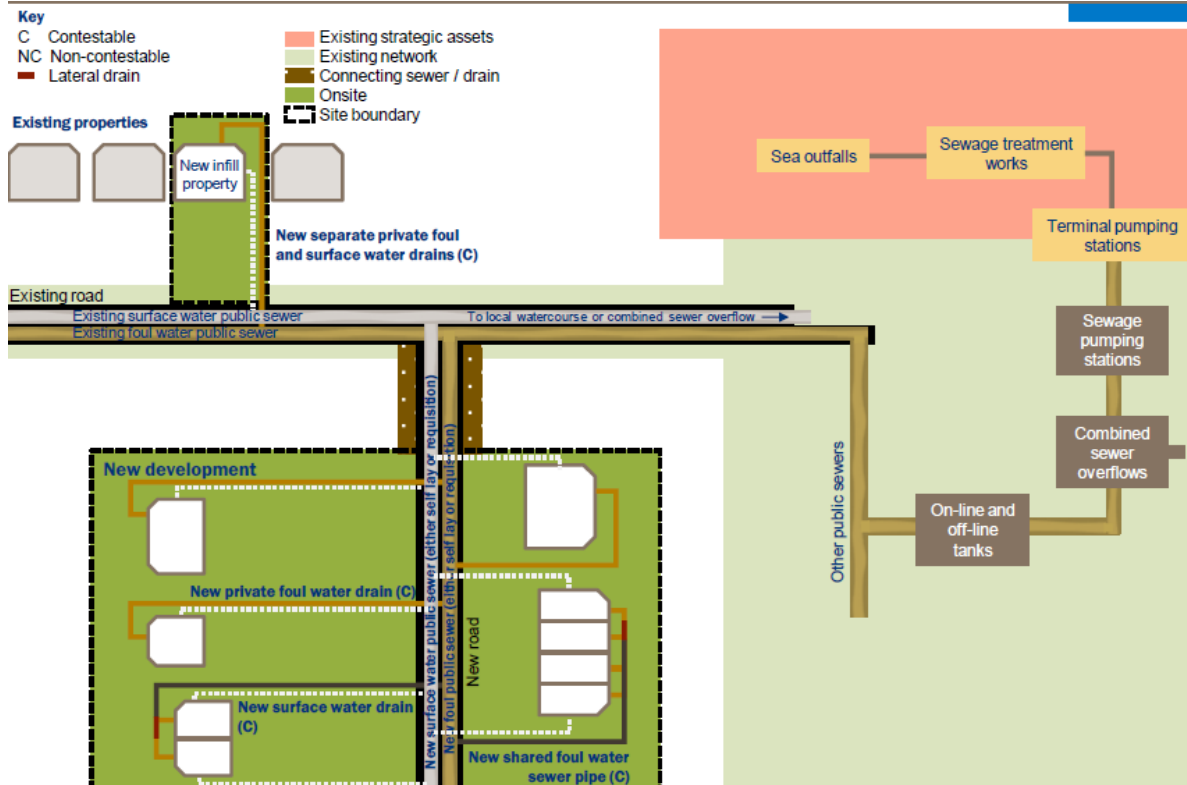

Figure 2-2 Public sewer network



2.1.6 Site Specific charge cap

Where we wish to specify a point of connection which is different from the nearest practical point, or we reach an agreement with the applicant on an alternative point of connection, the charge for site specific work will be capped. The cap will be equal to the lowest of the site specific charges that would otherwise be applicable if connecting at the nearest practical point on the existing network where the connecting pipework is of a no larger nominal bore than that of our existing network.

2.1.7 Exceptions to providing upfront requisition and diversion charges

We offer fixed upfront charges for water supply and wastewater requisitions and diversions where the works involved are simple in nature. That is, we have reasonable knowledge and understanding of the costs, potential risks and external factors that could affect the scheme.

We reserve the right to seek further costs from you should there be any change of scope, change in information provided to us or any other change that results in it not being reasonable for us to carry out the requisition or diversion on the basis of a fixed upfront charge.

Water supply requisitions and water main diversions

Where you requisition a water supply main or request a water supply main diversion (under sections 41 or 185 of the Water Industry Act 1991) we will offer you a price for the scheme based on the fixed charges set out in these charging arrangements if it is reasonable for us to do so.

Where the included works are affected by external factors outside our control, are subject to known or unknown site specific risks and uncertainties or involve a degree of complexity in delivering the scheme which would make it unreasonable for us to provide an upfront charge we will provide you with a high-level bespoke estimate.

The high-level bespoke estimate will be designed to fairly recover the costs incurred in delivering the scheme. It will consist of a brief description of the works involved and a site specific budget price estimate for the whole scheme, taking into account the level of detail and information available to us at the time.

Should you decide to proceed with the scheme, based on the bespoke estimate, it will be delivered on a rechargeable basis with any savings achieved returned to you and any additional costs incurred payable by you.

Instances where you will be offered a bespoke price estimate include, but are not limited to:

- Laying of water mains:
 - 300mm or greater in diameter; or
 - involving valve complexes; or
 - requiring a shut down or supply interruption to sensitive organisations or a significant number of customers.
- Where entry to lay or access to the pipe is required through:

- land in multiple ownership or occupation;
- land designated or planned for premium use;
- land subject to protracted negotiation or dispute; and
- land owned by a protected undertaker (e.g. land owned by Network Rail or the Crown, rivers or motorways).
- Where laying the main would involve crossing a river or motorway.
- Where we are unable to serve statutory notice for the works or require the consent of a 'protected undertaker'. E.g. crossing land owned by Network Rail, the Ministry of Justice, the Ministry of Defence or the Crown.
- Where ground conditions are particularly difficult (e.g. excavation of rock or artificially hard material) or require temporary or specialist works.
- Where the work to be carried out is close to or in land with particular environmental, historical or archaeological characteristics or in a flood plain.
- Where services or other utility assets (including our own) are discovered or known to be located in close proximity.
- Where the works involved are subject to third party or consenting authority restrictions, constraints or refusals (such as night working);
- Where road closures affect major junctions or where high speed traffic management is required.

There may be occasions where providing an indicative estimate is not possible or where the estimate will not meet the degree of confidence desired by you. In such cases, we will discuss with you the best way to proceed.

Wastewater requisitions and sewer diversions

Where you apply to requisition a sewer or request a sewer diversion from us (under sections 98 or 185 of the Water Industry Act 1991) we will offer you a price for the scheme based on the fixed charges set out in these charging arrangements if the construction work required is simple.

That is:

- The total length of sewer (gravity and pumped) is less than 100m in length.
- Any gravity sewer is no more than 300mm in diameter or deeper than 3m.
- Any pumped sewer is no more than 80mm in diameter or deeper than 1.5m.
- The ground conditions require no temporary or specialist works.
- All waste excavated is classified as inert.
- Where entry to lay or access the pipe is through land that:
 - Is owned and occupied by a single legal interest;
 - Is scrubland, moorland or bare agricultural land which is pasture or arable; and
 - Has no development premium hope value.
- Where we are able to serve statutory notice for the works and do not require the consent of a 'protected undertaker'.

Where the included works are affected by external factors outside our control, are subject to known and unknown site specific risks and uncertainties or involve a degree of complexity in delivering the scheme which would make it unreasonable for us to provide you with an upfront charge, we have set out in section 2.1.8 our stage gate process.

Examples of where our stage gate process shall apply include, but are not limited to:

- The laying of sewers involving any of:
 - pumping stations or treatment works;
 - the disposal of waste other than inert;
 - the location and diversion of other services;
 - work where ground conditions are particularly difficult (e.g. excavation of rock or artificially hard material) or require temporary or specialist works;
 - over pumping of existing flows;
 - dewatering of ground water;
 - the provision of site security;
 - work where the construction period is greater than 12 months;
 - work with restricted access;
 - work with constraints such as night working or other restrictions;
 - work being carried out close to or in land with environmental, historical or archaeological characteristics or in a flood plain;
 - where road closures affect major junctions or where high speed traffic management is required;
 - where entry to lay or access the pipe is required through:
 - land in multiple ownership or occupation;
 - land consisting of residential or non-residential gardens and amenity use;
 - land consisting of woodland, market gardens, allotments or a specialist agricultural use;
 - land designated or planned for premium use; and
 - land subject to protracted negotiation or dispute.
 - where laying the sewer would involve crossing a river or motorway;
 - where we are unable to serve statutory notice for the works or require the consent of a 'protected undertaker'. E.g. crossing land owned by Network Rail, the Ministry of Justice, the Ministry of Defence or the Crown.

In the first instance, the stage gate process provides you with a high-level feasibility assessment and budget price estimate. Should you decide to proceed with the scheme it will be delivered on a rechargeable basis with any savings achieved returned to you and any additional costs incurred payable by you.

Our stage gate process provides you with the opportunity to understand and control your phasing of spend on the project and only requires you to pay up front the costs for the next stage of the project.

2.1.8 Stage Gate Process

Our stage gate process is subject to contract and is designed to offer a fully rechargeable site specific bespoke solution. To proceed we will ask for a deposit against the full cost of the scheme that will be refundable in part if you at any point you decide not to proceed. The deposit is calculated at £2k, £5k and £10k for small, medium and large site works respectively. For very large, complicated or unusual sites a bespoke deposit will be discussed and explained to you.

A primary advantage of our stage gate process is the improved cash flow of this solution over full upfront charges.

The stage gate process provides you with a better understanding of the phasing and progression of the project. You are only required to pay for the next stage of the project before it commences. You will be given early warning of any risks that may affect the outturn costs of the project and there is a settlement charge or a refund at the end of the scheme which means you only pay what the project costs to deliver.

Figure 2-3

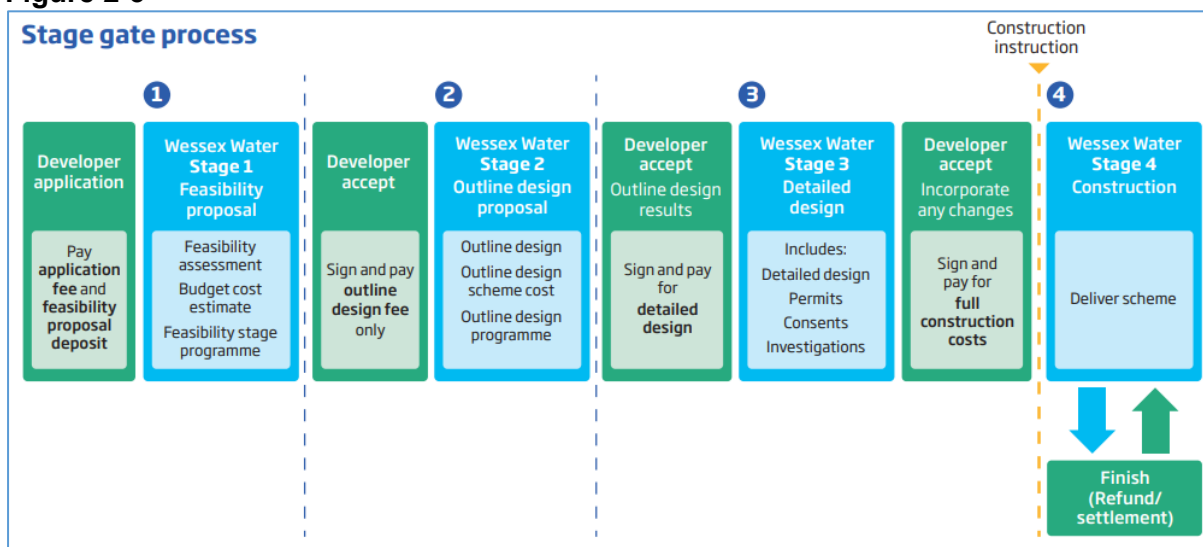

2.2 Income offset

Our philosophy is to set charges on a cost reflective basis so that customers pay the full cost of any work undertaken by us. The income offset arrangement is applied to infrastructure charges in accordance with legislative requirements (to take into account future income received from new households connected to our network) and means that our other customers contribute towards the costs of improvements to our existing network required to serve new development.

The government has made clear that it believes the current balance between contributions to costs borne by new connection services' customers and billpayers should be broadly maintained². Historically, the contribution made by billpayers is circa 11% of the cost of new development, with new connection services' customers paying the remaining 89% of costs. This balance of charges will be maintained, having due regard to our total forecast expenditure and the revenue we expect to be received from water and sewerage developments, for our 2024-25 charges.

² [Water Industry: Charging Guidance to Ofwat for Water and Sewerage Connections \(publishing.service.gov.uk\)](https://publishing.service.gov.uk)

In October 2021, Ofwat published its decision “[Scope and balance of developer charges and incentives - conclusions](#)”, in response to an earlier consultation, that from April 2025, they will remove the rule to maintain the balance of charges and therefore any income offset.

Not providing an income offset means that new connection services’ customers pay the full cost of new development with no contribution made by existing customers.

We provide an income offset to ensure that the balance of charges is broadly maintained. However, following the Ofwat decision, this will be the last charging year in which this will apply:

- We expect to incur £13.1m of cost providing services for new connections in 2024/25. To maintain the 89% balance of charges, we aim to recover £11.7m in revenue in the next year, a reduction of £1.4m.
- We expect to recover £5.4m of infrastructure costs during that time. Taking account of the income offset, this reduces the final amount to recover from new connection services’ customers to £4.0m.
- To achieve these reductions we will offer an income offset on infrastructure charges of 65% for water and 16% for sewerage in 2024/25.

2.3 Transitional arrangements

These Charging Arrangements come into effect from 1 April 2024.

2.3.1 Introduction

Although the new charging rules come into effect for work quoted on or after 1 April 2024, we recognise that some work will be quoted prior to this date. These quotes would have been drawn up using previous Charging Arrangements. We will use the following rules to determine whether the 2023/24 or 2024/25 charging arrangements apply:

2.3.1.1 Quotes issued prior to 1 April 2024

Before 1 April 2024, for all quotes issued under the 2023/24 Charging Arrangements:

- a. If your work has commenced, you cannot ask for a re-quote under the 2024/25 arrangements.
- b. If your work has not commenced, you can ask for a re-quote under the 2024/25 arrangements after 1 April 2024. Please note that the relevant application or administration fees will apply.

To confirm if your existing quote is still valid, please refer to section 2.4 below.

2.3.1.2 Quotes issued on or after 1 April 2024

For work quoted for and commencing on or after 1 April 2024, the charges in these Charging Arrangements will apply.

2.3.1.3 Re-quotes on or after 1 April 2024

If a developer accepts and pays a quote issued under 2023/24 Charging Arrangements but work has not commenced, and then requires a re-quote on or after 1 April 2024, the 2024/25 Charging Arrangements will be used to calculate the re-quote.

If an SLP/Developer has an active adoption agreement that was issued under the 2023/24 charging arrangements and then requires a Significant Variation on or after 1st April 2024,

the 2024/25 charging arrangements will be used as the new basis for the agreement. (See section 19.2 Water Adoption Agreement).

If customers ask for a requote at any time, we will apply the relevant fees.

For more information on how long your re-quote will be valid for, please refer to section 2.4 below.

2.3.2 Legal Agreements

Where a legal agreement is already in place, then the charges within that agreement remain valid for the life of the agreement, unless we agree to vary those charges with you.

2.3.3 Inflation

Charges relating to former charging rules or a previous year's charging arrangements, will be adjusted by inflation if the quotation or legal agreement includes an appropriate provision for adjusting the charges.

2.3.4 Infrastructure Charges

The value to be paid will be that set out in the charging arrangements that were in force at the time of your quote or offer letter, if you accept (pay) that quote or offer letter in accordance with the validity terms laid out in section 2.4. We reserve the right to make adjustments for inflation where there is a time lag between your quote or offer letter and commencement of the works that falls outside the validity terms.

2.4 Validity of Quotations

A summary of our quotation validity for our suite of charges is presented below. Please see the relevant sections for a detailed description of our charges.

Activity:	Legislation:	Quote valid for:	Once paid, quote valid for a further:
Supply Connection to existing main	S45	Minimum 1 month period or to the end of the financial year	3 months
Waste Connection to existing main	S106/S107	Minimum 1 month period or to the end of the financial year	3 Months
Self Lay - Supply mains adoption	S51	6 months	12 months
Supply requisition	S41	6 months	6 months
Waste requisition	S98	6 months	N/A
Supply Diversion	S185	6 months	N/A
Waste Diversion	S185	6 months	N/A
Adopting existing/new Waste assets	S102/S104	N/A	N/A

Any refresh of quotations will be at the prevailing rates at the time.

2.5 Statement of Significant Changes

2.5.1 Introduction

The Statement of Significant Changes for the 2024-25 New Connection Services Charging Arrangements sets out any significant changes in charges for 2024-25 and indicates whether bills for typical developments are to increase by more than 10% from the previous year.

The Board of Directors has assessed the effects of the new charges on customers' bills for the scenarios set out in Ofwat's *Common Terms and Worked Examples – English New connection Rules* published in October 2021. On that basis, and with regard to typical developments as set out below, we do not anticipate any bill increases of more than 10% from the previous year.

A summary of year-on-year charges is included in the below tables. Where our current year scenarios have been updated to reflect best practice, we have adjusted the previous comparison year to compare like-with-like.

2.5.2 Analysis of bills for typical developments

We based our scenarios on those provided by Ofwat's *Common Terms and Worked Examples – English New Connection Rules*. However:

- Wastewater connection costs are not included as, in most cases, this work is not undertaken by Wessex Water. However, we reserve the right to make the connection ourselves under S107 of the Water Industry Act 1991 and different charges would therefore be applicable.
- Wessex Water has the policy of only using barrier pipes in our service connections and our charges reflect this.
- Our application and administration charges are combined.

Our scenarios are set out in full in Appendix B using Ofwat's formatted tables.

Using our published cost calculator template, each scenario can be found on [Our charges documents \(wessexwater.co.uk\)](#) with the detailed buildup of relevant charges. A summary of the scenarios are displayed in the following tables (figures may not add up due to rounding):

Single connection

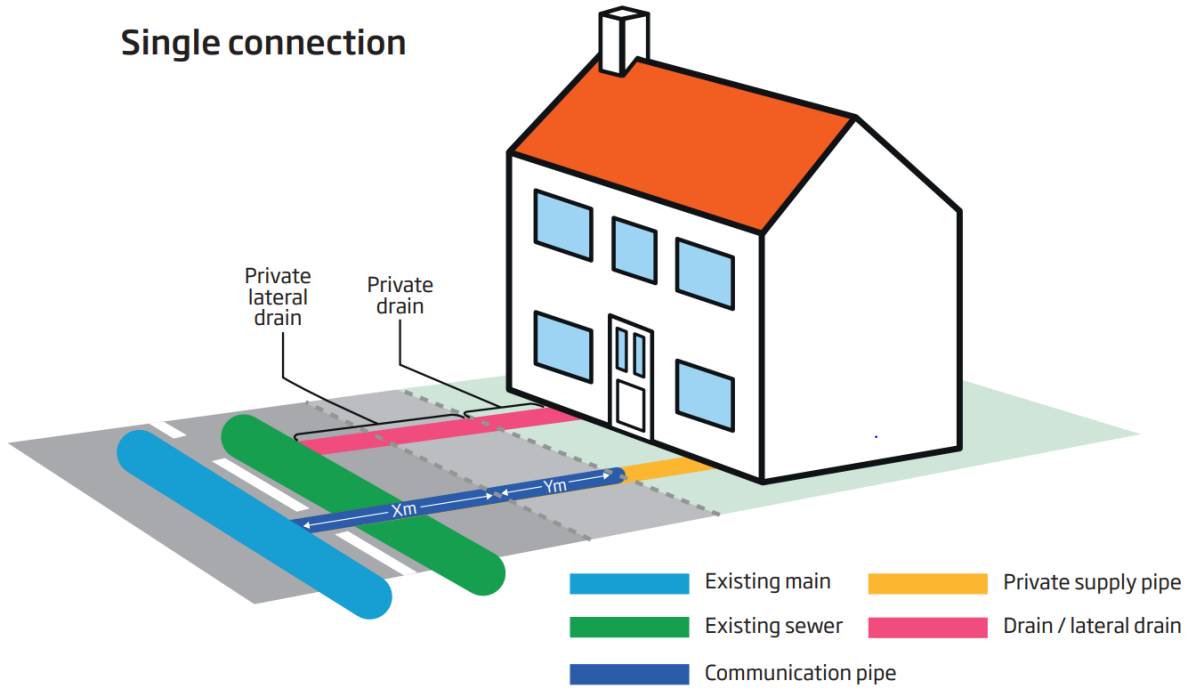

Scenario 1: Single connection to a house from an existing main

	2024-25	2023-24	% Change
Connection Charges (£k)			
- Non-contestable	0.4	0.4	
- Contestable	2.2	2.1	
Requisition Charges (£k)			
- Non-contestable	0.0	0.0	
- Contestable	0.0	0.0	
Infrastructure Charges (£k)	0.7	0.5	
Income Offset (£k)	-0.2	-0.1	
Total Developer Contribution (£k)	3.1	2.8	7%

Alternative Delivery Method*

SLP

	2024-25	2023-24	% Change
Connection Charges (£k)			
- Non-contestable	0.2	0.2	
- Contestable	0.0	0.0	
Requisition Charges (£k)			
- Non-contestable	0.0	0.0	
- Contestable	0.0	0.0	
Infrastructure Charges (£k)	0.6	0.5	
Income Offset (£k)	-0.2	-0.1	
Total Developer Contribution (£k)	0.7	0.6	9%

*Charges for Alternative Delivery Method are in addition to those charges the SLP imposes on the customer

New block of 10 flats

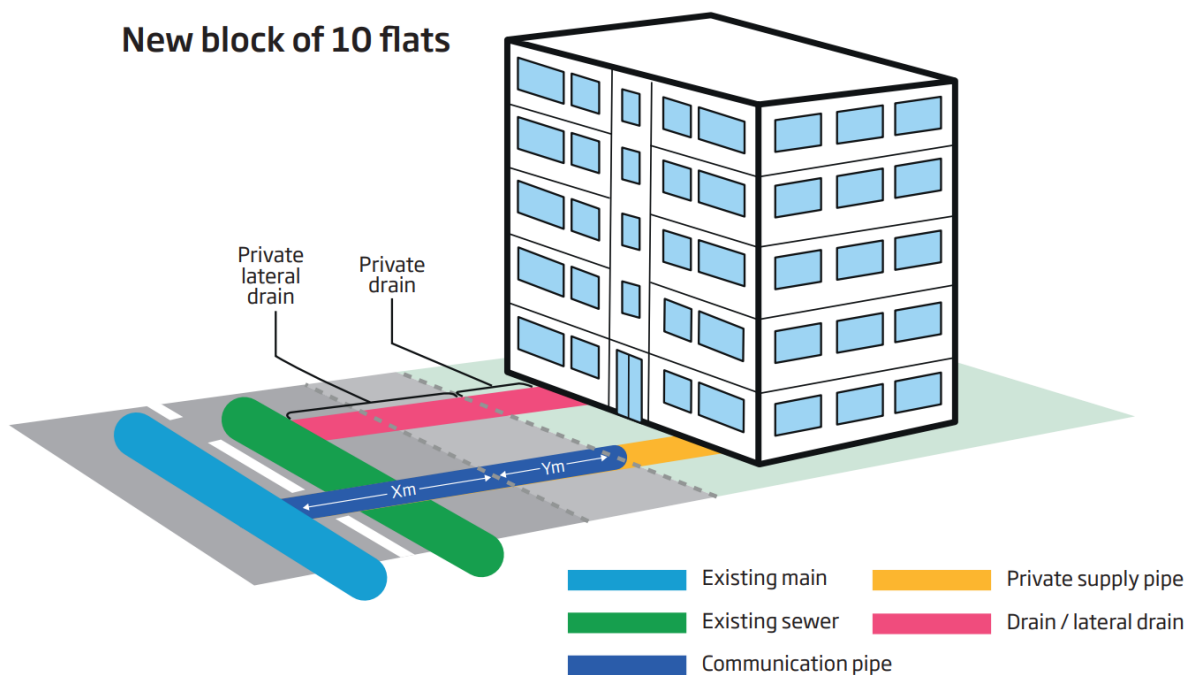

Scenario 2: Single connection to block of flats from an existing main

	2024-25	2023-24	% Change
Connection Charges (£k)			
- Non-contestable	0.7	0.6	
- Contestable	4.8	4.4	
Requisition Charges (£k)			
- Non-contestable	0.0	0.0	
- Contestable	0.0	0.0	
Infrastructure Charges (£k)	2.9	2.5	
Income Offset (£k)	-1.5	-1.0	
Total Developer Contribution (£k)	6.9	6.5	6%

Alternative Delivery Methods*

	SLP			NAV		
	2024-25	2023-24	% Change	2024-25	2023-24	% Change
Connection Charges (£k)						
- Non-contestable	0.5	0.5		0.2	0.2	
- Contestable	0.0	0.0		0.0	0.0	
Requisition Charges (£k)						
- Non-contestable	0.0	0.0		0.0	0.0	
- Contestable	0.0	0.0		0.0	0.0	
Infrastructure Charges (£k)	2.9	2.5		2.9	2.5	
Income Offset (£k)	-1.5	-1.0		-1.5	-1.0	
Total Developer Contribution (£k)	1.9	2.0	-1%	1.7	1.7	-2%

*Charges for Alternative Delivery Method are in addition to those charges the SLP/NAV imposes on the customer

Medium housing development

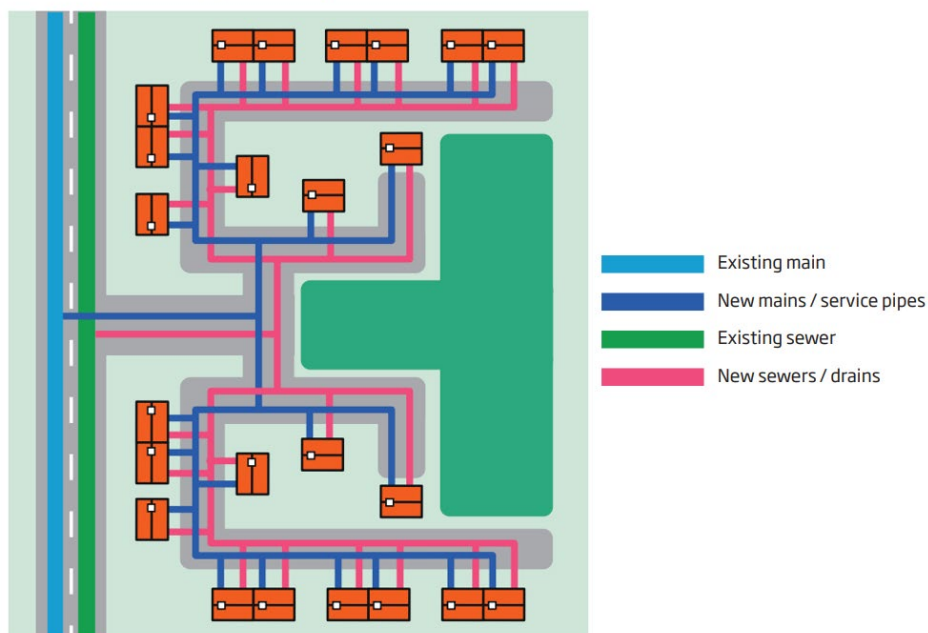

Scenario 3: Medium housing development requiring new mains and communication pipes (50 houses) Excavation/Reinstatement by Others

	2024-25	2023-24	% Change
Connection Charges (£k)			
- Non-contestable	1.9	1.9	
- Contestable	19.1	18.0	
Requisition Charges (£k)			
- Non-contestable	8.2	7.3	
- Contestable	35.0	36.7	
Infrastructure Charges (£k)	14.7	12.4	
Income Offset (£k)	-7.3	-4.9	
Total Developer Contribution (£k)	71.6	71.3	0%

Scenario 4: Medium housing development requiring new mains and communication pipes (50 houses) Excavation/Reinstatement by Wessex Water

	2024-25	2023-24	% Change
Connection Charges (£k)			
- Non-contestable	1.9	1.9	
- Contestable	59.4	55.6	
Requisition Charges (£k)			
- Non-contestable	8.2	7.3	
- Contestable	47.2	53.5	
Infrastructure Charges (£k)	14.7	12.4	
Income Offset (£k)	-7.3	-4.9	
Total Developer Contribution (£k)	124.0	125.7	-1%

Medium House Development (50 houses) Alternative Delivery Methods*						
	SLP			NAV		
	2024-25	2023-24	% Change	2024-25	2023-24	% Change
Connection Charges (£k)						
- Non-contestable	1.6	1.5		0.2	0.2	
- Contestable	0.0	0.0		0.0	0.0	
Requisition Charges (£k)						
- Non-contestable	8.2	7.3		8.2	7.3	
- Contestable	4.6	5.0		0.0	0.0	
Infrastructure Charges (£k)	14.7	12.4		14.7	12.4	
Income Offset (£k)	-7.3	-4.9		-7.3	-4.9	
Total Developer Contribution (£k)	21.7	21.2	2%	15.7	15.0	5%

*Charges for Alternative Delivery Method are in addition to those charges the SLP/NAV imposes on the customer

Large housing development

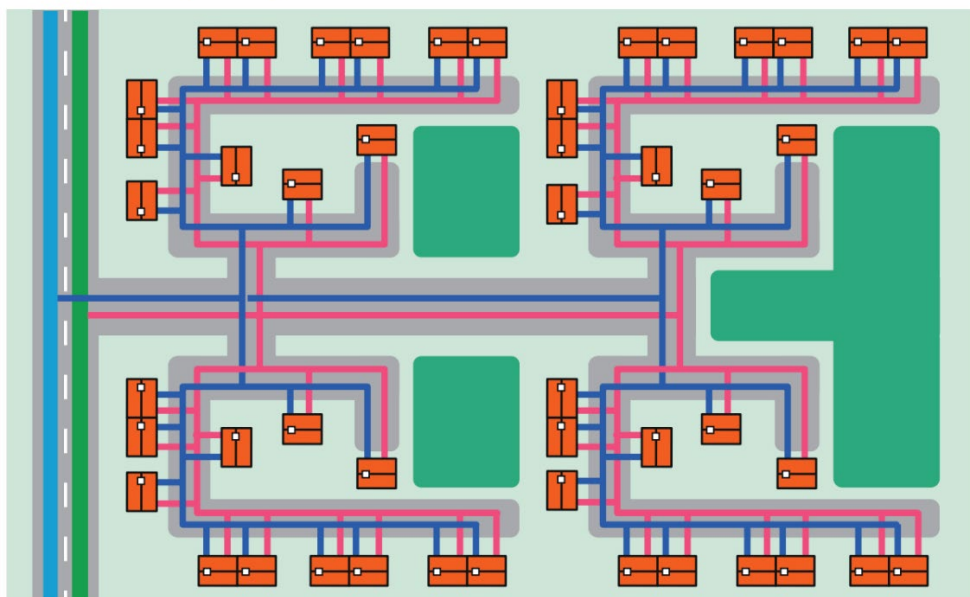

- Existing main
- New mains / service pipes
- Existing sewer
- New sewers / drains

Scenario 5: Large housing development requiring new mains and communication pipes (200 houses) Excavation/Reinstatement by Others

	2024-25	2023-24	% Change
Connection Charges (£k)			
- Non-contestable	6.9	6.7	
- Contestable	76.4	71.8	
Requisition Charges (£k)			
- Non-contestable	8.2	7.3	
- Contestable	102.6	107.9	
Infrastructure Charges (£k)	58.6	49.6	
Income Offset (£k)	-29.4	-19.6	
Total Developer Contribution (£k)	223.3	223.6	0%

Scenario 6: Large housing development requiring new mains and communication pipes (200 houses) Excavation/Reinstatement by Wessex Water

	2024-25	2023-24	% Change
Connection Charges (£k)			
- Non-contestable	6.9	6.7	
- Contestable	237.6	222.2	
Requisition Charges (£k)			
- Non-contestable	8.2	7.3	
- Contestable	139.8	158.8	
Infrastructure Charges (£k)	58.6	49.6	
Income Offset (£k)	-29.4	-19.6	
Total Developer Contribution (£k)	421.8	425.0	-1%

**Large House Development (200 Houses)
Alternative Delivery Methods***

	SLP			NAV		
	2024-25	2023-24	% Change	2024-25	2023-24	% Change
Connection Charges (£k)						
- Non-contestable	5.6	5.4		0.2	0.2	
- Contestable	0.0	0.0		0.0	0.0	
Requisition Charges (£k)						
- Non-contestable	8.2	7.3		8.2	7.3	
- Contestable	7.0	7.6		0.0	0.0	
Infrastructure Charges (£k)	58.6	49.6		58.6	49.6	
Income Offset (£k)	-29.4	-19.6		-29.4	-19.6	
Total Developer Contribution (£k)	50.0	50.3	-1%	37.6	37.5	0%

*Charges for Alternative Delivery Method are in addition to those charges the SLP/NAV imposes on the customer

2.5.3 Assurance

Our Board of Directors has assessed the effects of the new charges on customers' bills for a range of different types of development prescribed by Ofwat. Further detail is given in the signed board assurance statement that we have published alongside this document.

2.6 Further information

We have set out further information and technical guidance in separate documents on our website (<https://www.wessexwater.co.uk/services/building-and-developing>) to help you understand what you need to do to connect your new property to our network. We are also happy to answer any questions you might have.

2.7 Frequently asked questions

Frequently asked questions	
How do I find out if Wessex Water supplies my area with water and sewerage?	This map shows the areas where we supply water services and or sewage services. You can also find out if we supply your area with water by entering your postcode into Water UK's Find your supplier .
Can I talk to someone about this document?	You can contact Developer Services on 01225 526 222 or 01225 526 333 between 8:30am and 4:30pm (Monday to Thursday) and 8:30am and 4pm (Friday).

3. Applying for a new connection

3.1 Connecting your property to our network

The type of connection you require could vary depending on the number of properties you are connecting and the distance between your development and our network. Technical guidance is set out in separate documents, which should be read in conjunction with these charging arrangements.

- For connections to our water network, you can choose to have your new service connections and water mains (if required) laid by us or an accredited third party (or self-lay provider). Some work will need to be undertaken by us, even if you choose an accredited third party, so you will need to tell us about progress of work on the site.
- For connections to our sewerage network, you can choose to have your connections and sewers laid by us or by a suitably qualified third party. Should you use a third party to lay sewerage pipes, once the pipes are laid to a satisfactory standard, you can ask us to adopt your pipes if they have been constructed to the appropriate standard (see technical guidance). Adoption means that ownership of the pipes transfers to us and we take over responsibility for maintenance.

Another alternative is for you to engage a New Appointment or Variation company (NAV) to supply new householders on your development with water and sewerage services (under a 'new appointment or variation'). The NAV may lay the pipes and other infrastructure required and buy bulk services (water and/or sewerage) from us. The NAV remains responsible for the infrastructure within the area of the development.

3.2 How do you apply for a new connection?

If you want to make a new connection to our network, you or your retailer will need to:

Complete an application form and:

- a) for water connections:
 - ensure you have obtained water regulations approval;
 - advise us that your trench and service pipe are ready to be inspected;
 - make payment; and
 - have works completed by Wessex Water or approved contractor
- b) for sewerage connections:
 - submit full drainage details;
 - advise on the point and method of connection to our system;
 - make payment; and
 - have works completed by Wessex Water or approved contractor.

3.3 How do you find out about our mains and sewers?

You may need to know where you can connect to our mains and sewers. Plans showing the approximate location of our water mains and sewers can be obtained either, online at <https://maps.wessexwater.co.uk/webapps/request-a-map/>, from our asset enquiries team

within Developer Services, or you can visit our offices and see these plans. Alternatively, plans showing the location of our sewers only can be viewed at local authority offices.

Figure 3-1 Example development plans

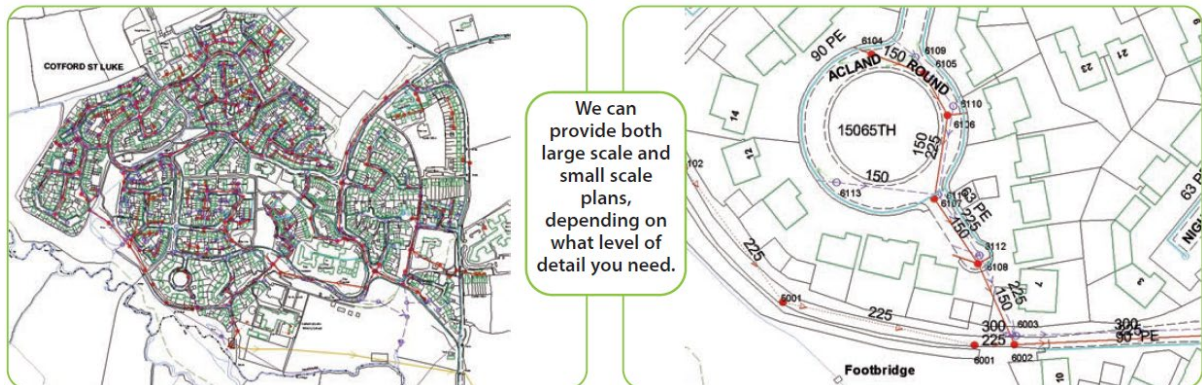

Reproduced from Ordnance Survey Map with the permission of the Controller of Her Majesty's Stationery Office. Crown copyright reserved, Licence No. 100019539

Table 3-1 Charges payable for asset plans and viability studies

Description	Unit pricing	Price
Extract of our network map (i.e. map of existing sewers or mains) – printed or sent electronically	Each	£15
Extract of company's network map (i.e. map of existing sewers or mains) – online access	Each	FREE
Pre-Planning Enquiry Response - to advise points of connection and/or discharge, capacity* and asset protection arrangements	per enquiry	FREE
Site Specific charge for the verification of Odour Modelling	per enquiry	£890

* If computer network modelling is required to assess capacity for a development that is neither allocated in a Local Plan nor has development management approval, we can still provide this service but it will be subject to payment of a fee. Please contact our planning liaison team for details.

If a proposed development site is close to a water recycling centre then, at pre-planning stage, odour modelling is required to take place. Where there is a need for you to understand if a development would have issues with odour this charge ensures we have the resource in place to provide you with the assistance required.

3.4 Abortive and additional visits

The Table 3-2 charges will apply where we:

- arrange to visit a site and the site is not ready or we are not able to carry out the work as arranged; or
- are required to reinspect a site or additional visits are deemed necessary; or
- if a customer amends the commencement date, you will be recharged for any costs we incur.

Table 3-2 Abortive and additional visit charges

Description	Unit pricing	Price
Any abortive site visit	per visit	£72 + any relevant costs
Additional site inspections	per visit	£151
If site is not ready, standing time for standard 3-man gang	per hour	£165
If site is not ready, abortive fees for standard 3-man gang	each visit	£2,516
If site is not ready, remobilisation charges for standard 3-man gang	as required	£1,258

3.5 Working in the Road

The below table of charges reflect the increased use of working in the road activities and their costs across projects, in alignment with highway regulations to increase safety.

As the highway regulations are controlled and managed by a third party (The local Highways Authority), it won't always be possible for us to include all applicable traffic management charges at the time of your quote. Where this is the case, you will be invoiced separately for any additional items, or refunded where items are no longer required, as applicable.

Table 3-3 Traffic management & road closure charges

Description	Unit pricing	Price
Streetworks permits*	Per charges published at the time by Highway authority area and local council	On application or check the relevant website for information
Road closure - signage	Per closure	£543
Person in attendance for traffic management**	Per day	£286
Suspend / bag off pedestrian crossing	Per crossing	£488
Suspend / bag off traffic lights	Per job	£709
Temporary 2 way lights	Per job	£191
Temporary multiway lights	Per job	£233
Designated parking bay suspension	Per job	£188
Temporary pedestrian crossing system	Per job	£784
Electronic variable message sign	Per week	£557

* Permit fees are set locally by the highway authority and vary considerably. Therefore, the appropriate charges, consistent with those published at the time of your application, will be added to your quote.

** The "person in attendance" is provided by our traffic management provider and is fully trained/qualified to do this work.

Please visit your local highway authority's website for more details of their fees. Any terms and conditions they apply to their charges will be passed through to you where appropriate, for example: applying a Highway Permit, fees for cancellation, variations or rescheduling of permits. At the time of our publication, there are a range of permit fees: £0-£130 and for road closures: £74-£345 depending on the highway authority and the type of road.

Additionally for road closures, the council charges to apply a Temporary Traffic Restriction Order (TTRO). At the time of publication, examples are: Devon £865 and Wiltshire £1,850. Please visit your local highway authority website for further details and their terms and conditions which we will pass through to you.

If you need any assistance finding Highways or Council permit fees, please contact us.

Road Closure requirements are defined in the Safety at Street Works and Road Works (A Code of Practice) Red Book. Where you require an expedited acceleration of the approvals of a road closure, where applicable and permitted by the relevant Highways Authority, a separate charge will be invoiced as a pass-through cost (currently costs vary to approx £1000). In such cases, the timing of the approval of the road closure remains at the discretion of the Highways department and is not guaranteed.

4. New water supply connections (s45)

4.1 Do you need to connect to our supply network?

If you want mains water for domestic purposes in your new development, you will need to connect to our water supply network. This means that you (or your contractor) will need to lay a private service pipe that can be connected, at your expense, to the nearest suitable water main. If your development requires water supplied for non-domestic purposes, please contact us separately to discuss.

A single house may require a small diameter water pipe laid from an existing main to the boundary of the property where a meter chamber and stop-tap (valve) is normally located. This is known as a service connection and this section of pipe is referred to as the communication pipe. A small diameter private supply pipe within the boundary of the property links the communication pipe with the internal plumbing of the house.

To ensure you have access to potable water, you will need to make a new water supply connection between your new development and our water network. Figure 4-1 will help you understand whether you need a new supply connection.

Figure 4-1 New service connection

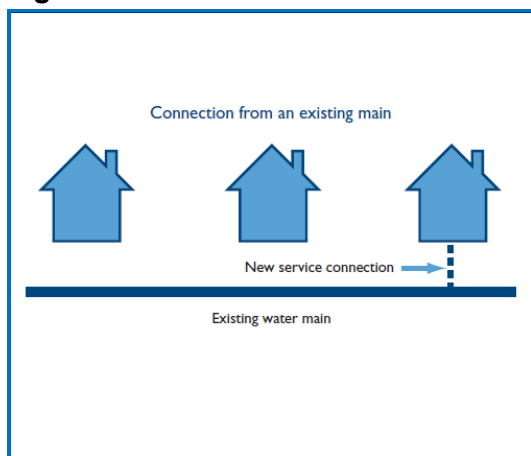

4.2 Who can connect your property to our water supply network?

We can connect your new development to our network and undertake all the works required. To protect our network and our customers, some work, described as non-contestable, can only be undertaken by us, whereas contestable work can be undertaken by you, your contractor or an accredited third party/self-lay provider.

You might consider the option of appointing a NAV to serve your development: if you take up this option, the NAV would undertake the non-contestable and contestable works required, and may buy bulk services from us to serve your development.

4.3 Our charges – connecting to our water supply network

Each new (water) connection includes the installation of a meter box, meter and 2m (linear) pipe-laying, excavation and reinstatement. Our charges reflect the costs we incur, including those we pass on from third parties, such as local councils' traffic management fees.

Where we don't have the statutory power to access the land, additional charges may apply. Please contact us to discuss your needs.

If you need to install fire hydrants for new builds, charges for these activities are found in our wholesale charges scheme, published on our website. Where there is a requirement for installing fire hydrants by the fire brigade, the costs we incur will be borne by the fire and rescue authority concerned.

We recognise that you may need help understanding what works you require. We are happy to help and can arrange a site visit so that we can assess what you need to make the connection to your new development.

4.3.1 What charges are payable?

Table 4-1 sets out the non-contestable administration charges for different elements of work required to make a connection to our mains.

Table 4-1 Service connection administration charges (non-contestable) Section 45

Description	Unit pricing	Price
Administration and application fee where Wessex Water makes the connection (first connection)	per connection	£122
Administration and application fee where Wessex Water makes the connection (each subsequent connection)	per connection	£33
Administration fee where an Accredited Third Party makes the connection (first connection)	per connection	£40
Administration fee where an Accredited Third Party makes the connection (each subsequent connection)	per connection	£27
Trench inspections (where we inspect service pipes laid by others)	per trench	£45

Table 4-2 shows our charges if we undertake the contestable works you require. Contestable works are those that can be done by another provider so you might want to compare our charges with a firm quotation from another provider. As summarised in 2.4, our quotations are valid for the longer of a minimum 3 month period or to the end of the financial year and after that you will need to re-apply. Once you have paid, our quotation is guaranteed for a further 3 months.

Table 4-2 Service connection charges (contestable) Section 45

Description	Unit pricing	Price
Point of connection enquiry (where the customer has not selected the point of connection)	per enquiry	FREE
Design of service connection (where contestable)	per application	FREE
With Excavation by Wessex Water:		
* Connection (≤ 32 mm diameter) to main including supply and installation of meter & meter box & up to 2 linear metres of service pipe	per connection	£923
* Additional connection (≤ 32 mm diameter) - No Excavation required including supply and installation of meter and meter box	per connection	£215
* Connection (> 32 mm diameter) to main including supply and installation of meter & meter box & up to 2 linear metres of service pipe	per connection	£1,560
* Additional connection (> 32 mm diameter) - No Excavation required including supply and installation of meter and meter box	per connection	£863
Supply and lay additional communication pipe in Verge/Unmade Ground (reinstate where required)	per linear metre	£265
Supply and lay additional communication pipe in Footpath (reinstate where required)	per linear metre	£432
Supply and lay additional communication pipe in Road (reinstate where required)	per linear metre	£535
Manifold Connection by means of four port manifold (four connections) including up to 2 linear metres of communication pipe	per manifold	£1,856
Manifold Connection by means of six port manifold (six connections) including up to 2 linear metres of communication pipe	per manifold	£1,900
With Excavation by Others:		
* Connection (≤ 32 mm diameter) to main (including supply and installation of meter & meter box)	per connection	£271
* Additional connection (≤ 32 mm diameter) including supply and installation of meter and meter box	per connection	£215
* Connection (> 32 mm diameter) to main (including supply and installation of meter & meter box)	per connection	£948
* Additional connection (> 32 mm diameter) including supply and installation of meter and meter box	per connection	£863
Manifold Connection by means of four port manifold (four connections)	per manifold	£1,244
Manifold Connection by means of six port manifold (six connections)	per manifold	£1,288
Other Applicable Charges:		
Supply and lay additional communication pipe without excavation	per linear metre	£37
Supply 15mm meter (non-AMR)	per meter	£46
Supply 15mm meter (AMR)	per meter	£94
Install and commission meter and/or meter box - labour only, components not included (only for meter types that necessitate a non-contestable delivery)	per meter	£31
Connection charge for building water (if not metered)	per plot	£95
Traffic management fees		Table 3-3
Road closure fees		Table 3-3

* Connections are contestable unless the work would present heightened risk to existing assets or could affect supplies to existing customers. Our definition of heightened risk is set out and reviewed annually as part of the Contestability Summary.

This can be found in the technical guidance documents [here](#).

4.4 Disconnection charges

If you decide you no longer require a water supply, you will need to apply for a temporary or permanent disconnection. Where a temporary disconnection is required, these charges are set out in our household and wholesale charges schemes.

No charges are made for a permanent disconnection from the mains water supply for domestic properties: we will make the disconnection at the point of connection to the main and not at the service end of the pipe to ensure the work is carried out correctly and we do not end up with any 'dead legs' (a length of pipe that water does not move through). We consider it appropriate that we cover this cost to reduce potential problems in our network. However, customers looking to remove multiple properties/connections from our network will be charged under a non-standard S185 (water mains diversion) due to the bespoke nature of the works.

Table 4-3 Disconnection charges (non-contestable) Section 62

Description	Unit pricing	Price
Permanent disconnection for domestic properties	each	FREE

4.5 Frequently asked questions

Frequently asked questions	
Can I connect to an existing private service pipe?	No – a separate connection is required direct from our public water mains.
How can I find out what pipe size and flow rates I require?	You will need to seek the advice of a suitably qualified plumber/engineer.
Do you lay all the pipework to my property?	No – we are responsible for making a connection on to the public water main and laying a pipe from the main to the boundary of your property. Normally you are responsible for laying the length of pipe from your property to the boundary, or an agreed point, which would be discussed at the time of survey.
Can I lay my pipe in the same trench as other utilities?	Yes – provided adequate clearance is provided between the water pipe and other utilities. Please see National Joint Utilities Group (NJUG) guidelines for requirements.
Where will my water meter be located?	Normally, the meter will be located at the boundary of your site or at the location of our water main.
What are water regulation fittings?	These are national requirements for the design, installation and maintenance of the internal water fittings (i.e., heating system, sinks, WCs etc). Their purpose is to prevent inefficient use of water and to prevent contamination.

5. Water mains requisitions (s41), adoptions (s51) and diversions (s185)

5.1 Do you need to lay (or divert) a new mains?

While some new developments may make use of private water sources, most developers need to be sure that all new properties on their new development can be supplied with mains water. This may require a new water main to be built to ensure there is sufficient water, at sufficient pressure to meet the expectations of new households living in the new development.

While all new developments require a service connection, not all new developments require a new mains. The diagram below is intended to help you understand whether you require a new water mains.

Figure 5-1 New mains connection

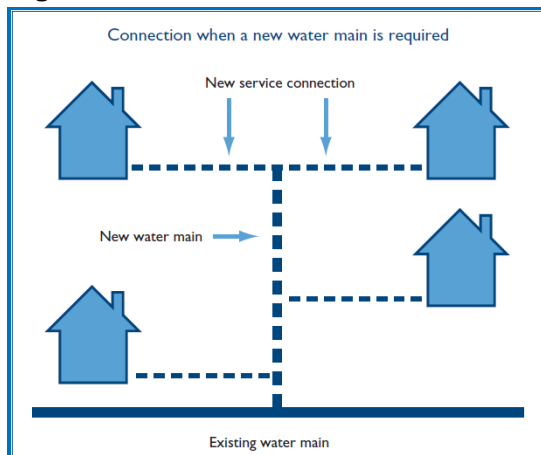

Section 4 sets out the charges for new service connections.

If an existing water main crosses a new development site, we would prefer the layout to be designed in such a way that it avoids the new mains, with agreed clearance. If this is not possible, the main can be diverted before any building works start.

5.2 Who can lay (or divert) new mains and make the connections?

Where new mains need to be laid (or diverted) this must be carried out in accordance with the National Joint Utilities Group (NJUG) guidelines on the positioning and colour coding of utilities apparatus, in order to safeguard the health and safety of our staff and to ensure that our apparatus remains accessible for future maintenance. So long as these guidelines are followed, you or your accredited third party contractor (SLP/NAV) can lay (or divert) the new mains, or you can ask us to do the work for you.

Mains are pressurised and carry large volumes of water so building near or over them is not permitted as it could lead to premature failure with potential risk to life and property or contamination risk.

A water main cannot be laid within the curtilage or enclosed gardens of any newly developed property as this could prevent accessibility for repairs and maintenance. We have legal rights

and powers to protect and ensure access to our assets. If you have any doubts or concerns in this regard you should contact us.

5.2.1 Non-contestable work that only we can undertake

We retain responsibility for certain work for reasons of network security and public health. We will undertake this work and where appropriate, we will make a charge to recover our reasonable costs.

A developer can requisition us to lay mains pipes and other necessary works (which might include a service reservoir or pumping station), in accordance with the arrangements set out in the Water Industry Act 1991.

5.2.2 Contestable work that any accredited provider can undertake

An WIRS (Water Industry Registration Scheme) Accredited Third Party may install water mains and make service connections subject to an adoption agreement being in place. Accreditation is required to satisfy us in advance of technical competence and experience of main-laying to safeguard public health and the integrity of our supply network.

More information about the WIRS accreditation process can be found by visiting WIRS (www.lrga.com).

5.3 Our charges – laying (or diverting) a new mains

In this section, we set out our charges for laying new water mains for your development. Our quotations are valid for 6 months. After this point if you wish to continue with the works you must request a review of that quotation. However once the quotation for a requisition is paid, it is guaranteed for a further 6 months from payment date.

For complex engineering projects where you requisition us to do the work (under section 41 of the Water Industry Act 1991), or if the works covers water mains of strategic importance, the upfront charges set out in these charging arrangements may not be available to you. Complex projects might include those where the project needs to cross railway tracks, motorways or rivers, or where the ground conditions are particularly difficult. Section 2.1.7 outlines these exceptions in further detail.

The costs and complexities of such projects mean that it would be unreasonable to expect that this work is priced on the basis of upfront fixed costs.

5.3.1 What charges are payable?

Table 5-1 and Table 5-2 show our charges for non-contestable and contestable work.

Table 5-1 Providing a public main as a Section 41 requisition (non-contestable) Section 41

Description	Unit pricing	Price
Mains administration and application fee	per application	£95
Mains design checking fee (applied whether design is done by us or third party)	per requisition	£253
Mains connection for connecting 49 properties or less that involves heightened risk to existing assets or could affect supplies to existing customers	per connection	£4,375
Mains connection for connecting 50 properties or more that involves heightened risk to existing assets or could affect supplies to existing customers	per connection	£7,871
Laying of additional mains where required to connect to nearest water main		Table 5-2

Table 5-2 Providing a public main as a Section 41 requisition (contestable) Section 41

Description	Unit pricing	Price
Point of connection enquiry (where the customer has not selected the point of connection)	per enquiry	FREE
Mains design fee (excluding checking fee)	per requisition	£460
Re-design fee where layout subsequently amended	per request	£249
Excavation by Others - Supply and lay pipe	per linear metre	£87
Excavation by Wessex Water - Supply and lay additional pipe in Verge/Unmade Ground	per linear metre	£125
Excavation by Wessex Water - Supply and lay additional pipe in Footpath	per linear metre	£147
Excavation by Wessex Water - Supply and lay additional pipe in Road	per linear metre	£232
Land entry agreements including compensation and legal fees	per linear metre	£31
Providing a booster where a customer desires guaranteed pressure greater than 0.7 bar at any point on the site	per booster	£172,783
Routine in-line mains connections (second connection of main in case of diversion)	per connection	£652
Pressure testing	per test	£519
Chlorination	per phase	£370
Sampling and undertaking standard analysis	per sample	£187
Traffic management fees		Table 3-3
Road closure fees		Table 3-3

We realise you may need help understanding what works you require so on receipt of an application and the application payment we are happy, if required, to arrange a site visit with an engineer so that we can assess what you need to make the connection to your new development.

If you need to install fire hydrants for new builds, charges for these activities are found in the Wholesale Charges document, published on our website. Where there is a requirement for installing fire hydrants by the fire brigade, the costs we incur will be borne by the fire and rescue authority concerned. Due to the scope of work and individual needs for all fire suppression requirements, each enquiry is evaluated on its own merits and a bespoke quotation for the works will be issued.

5.4 New appointments and variations (NAVs)

Where your development is to be served by a NAV, the NAV will own the mains and will take on responsibility for the assets. NAVs connecting to our network will need to purchase bulk supply and discharge services as required to serve the development and they will find information on their charges from us on our website.

5.5 Our charges – adoption of assets

Mains built by the developer/ WIRS Accredited Third Party will, subject to satisfactory design and installation, become part of our network and we will take over responsibility for those assets. Service pipes will not be adopted by us apart from any length up to and including the meter. This will usually be the pipework which falls within a street, known as the communication pipe.

5.5.1 Fees and deposit payable for vesting of mains assets

Where we adopt mains, we charge fees for service as shown in Table 5-3 and Table 5-4. Quotations provided are valid for 6 months and, once paid, the quotation is guaranteed for a further 12 months from payment date. Our legal agreement will automatically terminate if no works have started after 24 months.

Table 5-3 Adopting self-laid mains (non-contestable) Section 51

Description	Unit pricing	Price
Pre-commencement fee	per application	FREE
Re-inspection fee	per site visit	FREE
Legal agreement fee (for new agreements or reassessments of previous assessments)	per adoption	FREE
Service connection administration fees (where an SLP is providing these)	per connection	Table 4-1
(Excavate), supply and lay pipe (and reinstate where required)		Table 5-1

Table 5-4 Adopting self-laid mains (contestable) Section 51

Description	Unit pricing	Price
Mains design fee (excluding checking fee)	per design request	£460
(Excavate), supply and lay pipe (and reinstate where required)		Table 5-2

5.5.2 Ownership, operation and maintenance of the new mains

Ownership, operation and maintenance of the water mains rest with the customer until a vesting certificate is issued by us. Ownership, operation and maintenance of the service connection and communication pipe rests with us from the time of connection to the new main. The developer/NAV/SLP remains responsible for any defective materials and workmanship for an agreed Defects Liability Period (DLP).

5.6 Our charges – diversion of existing mains

If existing water mains cross a new development site and the layout cannot be designed to avoid them, they must be diverted if technically possible. You can propose a scheme and ask us to consider whether a diversion is possible.

5.6.1 What charges are payable?

For diversion of water mains up to but not including 300mm diameter, any Accredited Third Party provider can undertake the diversion work for you since this work is contestable, but you will need to pay our administrative charges.

For complex engineering projects where you requisition us to do the work or if the work covers water mains of strategic importance, the upfront charges set out in these charging arrangements may not be available to you. Section 2.1.7 outlines this in further detail and section 2.1.8 outlines the stage gate process we would use in these instances.

The appraisal & design fee covers our costs of determining how best to divert the mains, which may require us to undertake a detailed assessment of works required. If the work is not undertaken but we have incurred costs, we will refund part of the fee. Table 5-5 sets out our charges.

Table 5-5 Diverting water mains (contestable and non-contestable) Section 185

Description	Unit pricing	Price
Administration and Application fee	per application	£173
Design fee (where a main is to be diverted) (refundable in part)	per design	£2,133
Technical assessment fee (where the design for the diversion is provided by the customer)	per assessment	£257
Inspection fee (where the diversion work is provided by the customer)	per inspection	£251
Disconnection/reconnection of main (shut off)	per connection	£1,279
Disconnection/reconnection of main (line stop)	per connection	£5,549
Decommissioning redundant communication pipe	per linear metre	£32
Reinstatement of ground for washout/slucice valve installation	each	£203
(Excavate), supply and lay pipe (and reinstate where required)		Tables 5-1 & 5-2

6. New sewer connections (s106/s107)

6.1 Do you need to connect to our sewer network?

To ensure you can discharge your sewage into our sewer network, you will need to make a new sewerage connection between your new development and our sewerage network. If you require a new connection direct to a public sewer then you will need to apply to us for formal consent. You do not need to apply for connections to private soakaways, cess pits, septic tanks, treatment works or similar.

6.1.1 What connection do you need to make?

To connect to a public sewer you will either require a junction/saddle connection or you will make your connection via an existing or newly built manhole. Up to three dwellings can be connected to a Y or saddle junction; more than three dwellings must be connected via a new or existing manhole. More information can be found in our technical guidance documents.

6.2 Who can connect your property to our sewer network?

Depending on what type of connection you need to make, the work required may be contestable or non-contestable. Section 6.1.1 provides more detail on what type of connection is required in your circumstances.

6.2.1 Non-contestable works (connection via a Y junction or saddle)

Connections made to our sewer network by means of a Y junction or saddle connection will generally be non-contestable under section 107.

6.2.2 Contestable works (connection via a manhole)

Connections made to our network through an existing or new manhole are contestable work, which may be carried out by a suitably qualified contractor holding a Wessex Water permit card to work on sewers. Our technical guidance documents set out more information about accreditation.

6.3 Our charges – connecting to our sewer network

Table 6-1 sets out our charges. We do not undertake work on building sites to lay pipes for sewerage connections.

Table 6-1 Sewer connection charges (contestable and non-contestable) Section 106 & 107

Description	Unit pricing	Price
Administration, Application & technical approval fee	per application	£82
Connection by means of a Y-junction or saddle (including materials)	per connection	£441
Inspection of a connection via a manhole	per application	£116

The inspection fee covers up to two visits. All works must be carried out in accordance with the current edition of Water UK's Design and Construction Guide.

6.4 Frequently asked questions

Frequently asked questions	
What if I need to make a pumped connection?	Pumped systems are more complex than gravity systems and can pose a risk to the public sewerage system, particularly with regards to septic waste. Where a private rising main will discharge into a public sewer then a 'break' manhole must be constructed at the end of the rising main, to allow the flow to gravitate to the public sewer.
What is a lateral drain?	A lateral drain is a pipe that runs from the property boundary to connect to the public sewerage system. It is generally laid in third party land where land entry notice may need to be served, or in the highway. If necessary, Wessex Water can serve notice on third party landowners to allow a connection to be made. You can requisition a lateral drain from Wessex Water to serve a domestic property. This is a separate process to a connection application: more information is to be found in section 7.
Can I make a connection to a private drain?	Indirect connections may be made to suitable existing private drains, with permission being obtained from the owner of that drain. Technical approval and the inspection of indirect connections will be carried out by Building Control, not by Wessex Water. They may only wish to attend or formally approve the work if it forms part of a new build or significant extension. You can employ any groundworker to complete the work with the agreement of Building Control or your private inspector. Please be aware that any foul waste/rainwater that you connect will ultimately discharge to a public sewer. In certain cases, particularly with larger developments or where a rainwater connection is being proposed, you need to obtain our approval for the resultant flows.

7. Sewer requisitions (s98), adoptions (s102/s104) and diversions (s185)

7.1 Do you need to lay (or divert) a new public sewer?

If your proposed new development is not near an existing public sewer and/or you need to cross third party land to connect to our sewers, you can require ('requisition') us to lay a new public sewer from the nearest public sewer to the edge of the new development.

7.1.1 When can you requisition a new sewer?

Sewers are normally only requisitioned for domestic purposes to serve new development. The requisitioned sewer will be constructed by, or on behalf of Wessex Water. It is termed as a public sewer if it serves two or more properties, or a public lateral drain if it serves only one property.

Costs incurred in transferring or acquiring the freehold of land required for pumping stations or other sewerage assets will be included in the cost of the requisition.

Although legislation refers to requisitioning off-site sewers for domestic purposes, any commercial development containing an element of flows for domestic purposes, will be considered. Flows for non-domestic purposes may need trade effluent consent.

7.1.2 Who can requisition a new sewer?

Public sewers and lateral drains can be requisitioned by the owner or occupier of a property, or a developer, or the relevant local authority. You must have been granted full planning permission for a proposed development before sewer construction can start. If outline planning has been agreed, then appraisal can start while full planning is finalised.

To requisition a surface water sewer, you must have agreed formal discharge consent from the landowner of the watercourse where the outfall is to be located. Land ownership is the property alongside the watercourse. Without a discharge consent agreement in place, the sewer cannot be connected.

7.2 Who can lay (or divert) a new public sewer?

Subject to contract and at our sole discretion we may in some cases permit a requisitioner to design and construct at their cost a sewer or public lateral drain through third party land using our powers to construct the pipe under notice - A developer delivered requisition.

Under a developer delivered requisition we will serve statutory land entry notices but the full cost of the scheme including our costs in facilitating the developer delivered requisition and third-party compensation costs will be met by the requisitioner.

For the purposes of the Construction (Design and Management) Regulations 2015, under a developer delivered requisition contract the requisitioner will take on the role of client including the requirement to appoint the roles of principal contractor and principal designer as required.

For quality assurance purposes we reserve the right to comment on and approve the proposed design and contractor appointments. We will also inspect and test the works.

On completion of the works the requisitioner shall arrange a CCTV survey and production of as-constructed plans and levels.

The requisitioner shall ensure that all design and construction work is carried out by suitably qualified and experienced personnel and health and safety plans comply with our requirements for work on our sites and on our assets.

The requisitioner shall also be required to comply with our code of practice for the exercise of pipelaying powers on private land.

7.2.1 Non-contestable works

On some occasions, when a customer applies for a connection to our water supply or sewerage networks, or requisitions a new main or sewer, a check on the adequacy of our existing systems will need to be made.

7.2.2 Contestable works

Our technical guidance documents set out further details on developer delivered requisitions.

7.3 Our charges – laying (or diverting) a new public sewer

Where you requisition us to lay a new public sewer or lateral drain (under section 98 of the Water Industry Act 1991), the works involved are simple in nature and we have reasonable knowledge and understanding of the likely costs, potential risks and external factors that could affect the scheme outturn costs, the upfront charges set out below are available to you.

When the complexities of a requisition mean that it would be unreasonable to expect that this work is priced on the basis of upfront fixed charges, our stage gate process offers a fully rechargeable site specific bespoke solution and is set out below.

Section 2.1.7 outlines instances when the upfront charges or the stage gate process applies. Table 7-1 and Table 7-2 show our charges for non-contestable and contestable work where upfront charges apply. Our quotations are valid for 6 months and after that you will need to apply for a refresh if it is covered within the same charging year otherwise a full re-application will be required.

Table 7-1 Providing a public sewer or lateral drain (non-contestable) Section 98

Description	Unit pricing	Price
Administration & Application fee	per application	£337
Point of connection enquiry (where the customer has not selected the point of connection)	per requisition	FREE

Table 7-2 Requisition charges for new public sewers (contestable) Section 98

Description	Unit pricing	Price
Gravity Sewer - Supply and lay ≤225mm diameter pipe at ≤3m depth - Excavation by Water Company (reinstate where required)		
In field	per linear metre	£1,929
In made ground		£2,131
In road		£2,289
Gravity Sewer - Supply and lay >225mm & ≤300mm diameter pipe at ≤3m depth - Excavation by Water Company (reinstate where required)		
In field	per linear metre	£2,039
In made ground		£2,261
In road		£2,423
Pumped Sewer - Supply and lay 80mm diameter pipe at ≤1.5m depth - Excavation by Water Company (reinstate where required)		
In field	per linear metre	£1,279
In made ground		£1,346
In road		£1,556
Design & Installation of Sustainable Drainage Scheme (SuDS)	per scheme	Price on Application
Land entry agreements including compensation and legal fees	per linear metre	£31
Traffic management fees		Table 3-3
Road closure fees		Table 3-3
Decommissioning redundant pipe (if diverting a sewer under a section 185 diversion)	per linear metre	£32

The charges in Table 7-2 provide for up to:

- 4 nr chamber on gravity sewers;
- 1 nr air valve, washout chamber and connection for pumped sewer option; and
- nominal sum for design.

If there is not enough detail in the table above to price your project, then it is likely your project does not meet the criteria to be priced using our upfront charges and you will need to apply for a requisition following our stage gate process. Further information is included in section 2.1.8.

7.4 New appointments and variations (NAVs)

Where your development is to be served by a NAV, the NAV will own the sewers and lateral drains and take on responsibility for the assets. NAVs connecting to our network will need to purchase bulk supply and discharge services as required to serve the development.

7.5 Our charges – adoption of assets

We levy administrative charges where we adopt assets, whether they are existing or new.

7.5.1 Existing private sewage treatment works and/or private sewers (s102)

We can adopt private sewerage systems under section 102 arrangements. The adoption process requires the party applying for adoption to carry out an as-constructed survey and a structural survey of the assets they want us to adopt. We will inspect the system and advise if any repairs are required. Once we agree that the assets meet an acceptable standard, we will serve formal notice on the current asset owners and interested parties. After two months, if no objections have been raised, we will vest the assets and confirm the system has been adopted as public.

Where we propose to adopt an existing private treatment plant under this process and a sampling history cannot be provided as part of the submission, we will be required to undertake sampling for a minimum period of 6 months to ensure compliance with discharge consents prior to adoption. Please see technical guidance for more information. With regard to sewer adoption, this means the ownership and responsibility of the asset is transferred to us. You must pay all inspection fees and the cost of any remedial works required to ensure the sewerage system is to an acceptable standard before the sewers are adopted.

Table 7-3 shows our charges for non-contestable work.

Table 7-3 Adopting existing sewerage assets (non-contestable) Section 102

Description	Unit pricing	Price
Administration & Application fee	per application	£115
Technical approval	per application	£506
Inspection	per application	£488
Pumping Station compliance fee	per pumping station	£1,427
Land transfer fee	per agreement	£1,166
Pumping Station telemetry provision via cellular communications, as compliant with Design and Construction Guide (DCG) and Wessex Water's Associated Addendum	per installation	£2,928
Pumping Station telemetry provision for sites with no cellular communications and/or multiple inhibit links, as compliant with Design and Construction Guide (DCG) and Wessex Water's Associated Addendum	per installation	Price on Application
Excavate supply and lay pipe (and reinstate where required)		Table 7-2

7.5.2 New sewers and pumping stations (s104)

An adopted sewer is operated and maintained as a public asset by us. A private sewer is owned and maintained by the private owner or the local authority at their expense. Sewers constructed as part of a new development can be offered for adoption so that they are looked after by us in the future. Sewers and pumping stations need to be designed and built according to specifications in the latest version of Design and Construction Guidance. Adoption compliance fees cover the cost for us to confirm the asset is built to the requisite standard.

New pipes that only serve a single property and are entirely within that property's boundary will not be adopted and will remain the responsibility of the property owner. Adoption of new sewerage systems under a section 104 agreement is a separate process to a connection application. New manhole chambers built on an existing public sewer will automatically become part of the public system on completion.

You can ask us to consider adopting a private sewage treatment works where it serves 10 or more properties and includes at least one length of sewer upstream. Table 7-4 shows our charges for contestable work.

Table 7-4 Adopting new sewerage assets (non-contestable) Section 104

Description	Unit pricing	Price
Administration & Application fee	per application	£145
Technical approval (Initial Submission)	per application	£539
Technical approval (Subsequent submissions)	per re-submission of application	£216
Adoption compliance fee - for our estimated construction cost <£50k	fixed cost (up to 2 inspections per month)	£1,191
Adoption compliance fee - for our estimated construction cost £50k - £100k	fixed cost (up to 2 inspections per month)	£2,857
Adoption compliance fee - for our estimated construction cost £100k - £1m	fixed cost (up to 2 inspections per month)	£4,525
Adoption compliance fee - for our estimated construction cost >£1m	fixed cost based on our estimated construction cost	0.40%
Legal agreement fee (for new agreements or reassessments of previous assessments)	per agreement or per adoption	£594
Surety or deposit (if appropriate) (refundable in part)	percentage of our estimated construction cost	10% or minimum of £5,000
SUDS Adoption compliance fee	per SUDS	Price on Application
Deed of grant fee	per agreement	£935
Pumping Station adoption compliance fee	per pumping station	£1,427
Land transfer fee	per agreement	£1,166
Pumping Station telemetry provision via cellular communications, as compliant with Design and Construction Guide (DCG) and Wessex Water's Associated Addendum	per installation	£2,928*
Pumping Station telemetry provision for sites with no cellular communications and/or multiple inhibit links, as compliant with Design and Construction Guide (DCG) and Wessex Water's Associated Addendum	per installation	Price on Application
Excavate supply and lay pipe (and reinstate where required)		Table 7-2

* This price is only applicable if telemetry is installed within 2 years of the date of application. Thereafter the price will be subject to the charging arrangements in place at the time of installation.

The adoption compliance fee that will apply depends on the quoted construction cost and therefore one of the above fixed charges will apply. Each charge covers up to 2 inspections

per month. If more inspections are required, these will be charged additionally (additional inspection charges are included in Table 3-2. A flat fee is used for smaller sites, where inspection time is typically driven by size. For the biggest of sites (over £1m construction cost), a percentage is applied as inspection time is typically driven by the complexity of the site.

7.5.3 Sustainable Drainage Systems (SuDS)

We support SuDS which provide benefits of reduction in flood risk, improvement in water quality, biodiversity and amenity. Design and Construction Guidance, published by Water UK, clarifies in Part C the components of Sustainable Drainage Systems which can be adopted by Sewerage Undertakers. We will consider adoption of a wider variety of SuDS components including swales, ponds, rills and soakaways, if built to adoptable standards.

We do not adopt balancing ponds, culverted watercourses or rhydes, only the headwall(s) into them.

For further information and our SuDS policy please see [Sector guidance on sewerage and water adoption agreements](#) on our website.

7.6 Surety or deposit payments

Where we adopt new assets under section 104, we will require a surety or deposit.

- The surety has to be made with an appropriate body (e.g. National Housing Building Council), the determination of which is a matter for the customer and the appropriate body. On adoption of the assets, we will confirm that the surety can be released.
- The deposit will be based on our estimated construction cost, or a minimum of £5,000. We will calculate interest on the deposit from the date that the agreement between us and the customer is signed, until the date that the assets are adopted. We will return the deposit and interest payable to the customer once the assets have been adopted. The calculation of interest will be consistent with Ofwat's guidance on this.

7.7 Our charges – diversion of existing sewers

If there are sewers crossing a new development site and the layout cannot be designed to avoid them, they must be diverted if technically possible. You can propose a scheme and ask us to consider whether a diversion is possible.

We define three types of sewer diversion, shown in the table below.

Type of diversion	Works required	Is this work contestable?
Major diversion of critical sewer or rising main	If the site is large, or the diversion is complex, off site or on a critical sewer, Wessex Water will carry out the work. We will provide an estimated offer that includes appraisal, design and construction. You will need to deposit the estimated sum with us, and construction will be carried out on a rechargeable basis.	No
Major diversion	Depending on the importance of the sewer and whether other site works are involved, you may be allowed to carry out diversion works yourself using a suitable contractor. We will charge a technical assessment, inspection and legal fee, and you will provide a returnable deposit as surety.	Yes
Minor diversion	If the sewer is relatively shallow, of small diameter and only serving a few houses, we may allow you to divert the sewer yourself using your own contractor. We will advise if the sewer is minor and what standard of construction is required. This is only acceptable for low risk gravity sewers 150mm diameter or smaller, no more than 1.2m deep, and serving 25 properties or less.	Yes

7.7.1 What charges are payable?

For major and minor diversions, any suitable contractor can undertake the diversion work for you, since this work is contestable, but you will need to pay our administrative and application charges and a returnable cash deposit/bond (as long as the work is completed to the appropriate standard).

Table 7-5 shows our non-contestable charges and these will apply where works are simple in nature. Please refer to section 2.1.7 for exceptions to using our upfront diversion charges and to section 2.1.8 for the stage gate process we would use where in instances where using upfront diversion charges is not appropriate.

Our charges for sewer buildovers are included in our technical guidance documents.

**Table 7-5 Diverting a public sewer asset – major or minor diversion (non-contestable)
Section 185**

Description	Unit pricing	Price
Administration & Application fee (includes letter of agreement)	per application	£123
Technical assessment fee (where the design for the diversion is provided by the customer)	per assessment	£334
Inspection fee (where the diversion work is provided by the customer)	per site	£465
Surety or deposit (if appropriate)	percentage of our estimated construction cost	10% or minimum of £500 for minor diversion, or minimum of £5,000 for major diversion
Appraisal fee (where we divert a critical or major sewer) (refundable in part)	per appraisal	£2,000
Pumping Station compliance fee (for option 2 diversions)	per pumping station	£1,427
Land transfer fee	per agreement	£1,166
Pumping Station telemetry provision via cellular communications, as compliant with Design and Construction Guide (DCG) and Wessex Water's Associated Addendum - only chargeable under option 2 diversions where developer builds pumping station	per installation	£2,928*
Pumping Station telemetry provision for sites with no cellular communications and/or multiple inhibit links, as compliant with Design and Construction Guide (DCG) and Wessex Water's Associated Addendum - only chargeable under option 2 diversions where developer builds pumping station	per installation	Price on Application
Excavate supply and lay pipe (and reinstate where required) or decommission redundant pipe		Table 7-2

* This price is only applicable if telemetry is installed within 2 years of the date of application. Thereafter the price will be subject to the charging arrangements in place at the time of installation.

8. Water and sewerage infrastructure charges (s146)

8.1 What is an infrastructure charge?

Infrastructure charges are used to cover the cost of improving our existing network to cope with providing extra capacity for new developments. An infrastructure charge is payable by anyone who wishes to build or develop a property.

8.2 Do you need to pay an infrastructure charge?

You will be required to pay the infrastructure charge if you:

- build new premises, including houses, flats, commercial premises, institutions, permanent caravans that are subsequently connected to our network;
- convert existing premises such as a house into flats and thereby increase the number of connections required; or
- connect existing premises to our network for the first time.

The charge is payable for each new connection made. Where you already had a connection in place, we will take that into account in assessing the charge payable.

8.3 What work is required?

Demand from a new development can affect the performance of the existing infrastructure to an extent where reinforcement of the network (e.g. by construction of new mains, tanks, sewers, service reservoirs, pumping stations) is required to maintain service levels to customers. The infrastructure charge will be used to fund network modelling and capital investment to ensure that new developments are able to connect to our water and sewerage network with no deterioration of service for new or existing customers.

We are responsible for undertaking the work required to increase the capacity of our network. Network reinforcement work is non-contestable.

8.4 Our charges – network reinforcement

Our water and sewerage networks are complex and we have invested heavily in network reinforcement to anticipate new developments. We liaise with local authorities and new connection services' customers to understand their requirements and to ensure that our network has sufficient capacity to allow new developments. Our gross infrastructure charges will recover the cost of network reinforcement required for new development.

Our infrastructure charges for 2024-25 are based on the forecast cost of upstream and downstream network reinforcement across our region over the next five years. If your development requires bespoke arrangements and/or the drainage solution is complex then we would be happy to discuss this with you to determine an appropriate charge.

Upstream and downstream infrastructure investment to provide capacity is, by its nature, very long-term and can be exceedingly lumpy. We have a requirement to be cost reflective over the next five years.

We set out our calculation of infrastructure charges for 2024-25 and our 5 year forecast from 2024-25 in the table below.

Total forecast for 5 years 2024-29		
Network reinforcement expenditure	£m	39.9
Income offset to recover 89% of total expenditure ³	£m	1.4
Total we are aiming to recover	£m	38.5
Net income plus income offset	£m	39.9
Total to recover: supply	£m	6.4
Total to recover: waste	£m	32.1
<u>Forecast connections</u>		
Supply	nr	24300
Waste - no SW seperation	nr	15422
Waste - SW attenuation	nr	10281
Waste - full SW seperation	nr	25704
Full Charges - to cover expected costs		
Supply charge	£/unit	204
Waste charge - no SW seperation	£/unit	893
Waste charge - SW attenuation	£/unit	447
Waste charge - full SW seperation	£/unit	89
<u>Discounted Charges</u>		
Supply charge	£/unit	71
Waste charge - no SW seperation	£/unit	750
Waste charge - SW attenuation	£/unit	375
Waste charge - full SW seperation	£/unit	75

³ This is only calculated for 2024-25 following Ofwat's decision to remove this rule.

8.4.1 Water supply infrastructure charge

We will therefore set a gross infrastructure charge of £204 with the aim of keeping our discounted charges stable going forwards.

8.4.2 Sewerage infrastructure charge

We will therefore set a gross infrastructure charge of £893 for 2024-25, with the aim of keeping our discounted charges stable going forwards.

8.5 What is the income offset?

To ensure that the balance of charges between new connection services' customers and other customers is broadly maintained, we will apply an income offset to all infrastructure charges. The 2024-25 income offset for water supply is 65% and for sewerage is 16%. As this is the final year of applying income offset, any connections made after 31 March 2025 will not receive this discount. Section 2.2 provides more detail on how the income offset is calculated.

8.6 What charges are payable?

Table 8-1 and Table 8-2 show our infrastructure charges. Where you are building on a site that has previously been connected to our network, an infrastructure credit may be available. Where you are building non-standard properties, you will need to calculate the relevant multiplier. Sections 8.6.2 and 8.6.3 contain more information about these.

Table 8-1 Water infrastructure charges Section 146

Description	Unit pricing	Price
Infrastructure credits to account for relevant use within the last five years	Number of credits	-£204
Infrastructure charges due for the development	Per dwelling	£204
Credit for sustainable development consuming <100lpppd	Per dwelling	-£100
Relevant multiplier charges due for the development	Charge based on fittings	RM x £204
Income offset	% reduction	65%

This year we have included a new environmental incentive for those developer customers who provide evidence that a new property will consume less than 100 litres per person per day. This credit will be applied to the gross infrastructure charge before the application of income offset. You can find further details of the process to claim the credit on our website.

Table 8-2 includes different charges for new connection services' customers who commit to reducing the amount of surface water discharged into our sewers giving the dual outcome of benefitting the environment and lowering the charge rate you pay. This could be achieved either through the provision of a sustainable drainage scheme (SuDS) that attenuates the flow of surface water into our existing or proposed network or schemes that commit to zero surface water discharge into our existing or proposed network. Customers that wish to claim the lower charges will need to provide information on the applicable plots. If any rainwater run off will enter our network, an infrastructure charge will be applicable. For example this would cover self-fill petrol stations or other un-attended facilities where no other services are required from us.

Table 8-2 Sewerage infrastructure charges Section 146

Description	Unit pricing	Price
Infrastructure credits to account for relevant use within the last five years	Number of credits	-£893 / -£447 / -£89
Infrastructure charge due for development (no surface water abatement)	Per dwelling	£893
Relevant multiplier due for the development	Charge based on fittings (calculated by reference to table 8-3)	RM x £893
Infrastructure charge for schemes with the inclusion of an agreed SuDS scheme that attenuates the flow of surface water into our existing or proposed network	Per dwelling	£447
Infrastructure charge for schemes that commit to zero surface water discharge into our existing or proposed network	Per dwelling	£89
Income offset	% reduction	16%

8.6.1 Infrastructure charge credit

Infrastructure charge credits will be applied where the site has been connected to our network within the previous five years, to reflect the reduction in the need for network reinforcement.

The credit is applied by deducting the number of former dwellings connected on the site or by taking the metered consumption or discharge from the site and equating that to an average dwelling within our area to arrive at an equivalent number of dwellings. In the absence of metered information, other reasonable evidence should be used to estimate the prior demand on the network from the site.

8.6.2 The relevant multiplier

In certain circumstances where water is used for purposes other than flats or houses, as in commercial premises, schools, hotels etc, the infrastructure charge is calculated using the number and type of water fittings installed in the premises – known as the relevant multiplier (RM). The RM is calculated by adding up the loading units for all water fittings in the property and dividing by 24 (the total number of loading units for a standard dwelling). The RM is multiplied by the current water and sewerage infrastructure charges to arrive at the total charges for the property.

8.6.3 Loading units for calculating the RM

Table 8-3 sets out the loading units for non-standard properties.

Table 8-1: Relevant multiplier loading units for non-standard properties

Water fitting/appliance	Loading units
WC flushing cistern	2
Urinal	3
Wash basin in a house	1.5
Wash basin elsewhere	3
Bath (tap nominal size 3/4"/20mm)	10
Bath tap nominal size > 3/4"/20mm)	22
Shower	3
Sink (tap nominal size 1/2"/15mm)	3
Sink (tap nominal size > 1/2"/15mm)	5
Spray tap	0.5
Bidet	1.5
Domestic appliance	3
Communal or commercial appliance	10
Any other waste fitting or outlet	3
Indoor swimming pool	24

Notes to the table:

1. Any fitting includes any plumbing, outlet, dedicated space or planning or other provision for that fitting.
2. "House" means any building or part of a building which is, or will be, occupied as a private dwelling house. The expression includes a flat.
3. "Bath" includes a whirlpool bath or a jacuzzi.
4. "Domestic appliance" means an appliance (including a dishwasher, a washing machine and a waste disposal unit) in a house and "communal or commercial appliance" means an appliance (including a dishwasher, a washing machine and a waste disposal unit) elsewhere than in a house (including in communal facilities).
5. A minimum of six loading units shall be included for each house for domestic appliances (whether or not the house has any such appliances). This does not apply where neither a washing machine nor a dishwasher can be provided (and there is no plumbing, outlet, dedicated space or planning or other provision for either appliance) in the house.
6. Where premises have only a sewerage connection and there are no water fittings, the relevant multiplier will be one.

8.6.4 Using the relevant multiplier on a new development

Suppose that a new 20-bedroom hotel is built. Table 8-4 sets out its requirements and these are used to calculate the RM.

Table 8-2: Example relevant multiplier calculation

Water fitting/appliance	No. required	Loading units	Total proposed no l/u
WC flushing cistern	30	2	60
Urinal	3	3	9
Wash basin in a house	25	1.5	37.5
Wash basin elsewhere	3	3	9
Bath (tap nominal size 3/4"/20mm)	5	10	50
Bath tap nominal size > 3/4"/20mm)		22	0
Shower	20	3	60
Sink (tap nominal size 1/2"/15mm)	3	3	9
Sink (tap nominal size > 1/2"/15mm)		5	0
Spray tap		0.5	0
Bidet		1.5	0
Domestic appliance		3	0
Communal or commercial appliance		10	0
Any other waste fitting or outlet		3	0
Indoor swimming pool		24	0
Total			234.5
Total number of loading units divided by 24			9.77

The final row of this table will be multiplied by the relevant infrastructure charge.

8.7 Upsizing new assets for future use

Where it is reasonable to do so, we may propose that assets provided by developers, NAVs or SLPs should be upsized to provide capacity for later growth. Where assets are upsized as a result of our request, we will contribute towards the reasonable cost. The contribution will be based on assumed flow rates for the development relative to that of the other flows allowed for in the design.

Upsizing new assets to allow for future use is considered to be network reinforcement and we will take account of this type of investment when setting our infrastructure charges.

8.8 Network enhancement

Network enhancement refers to the process of dealing with pre-existing shortfalls in capacity that are not the consequence of new development. The cost of addressing pre-existing shortfalls in capacity, greater demand from existing properties, enhancing the network's performance, or improving network flexibility may not be recovered through the infrastructure charge. Such enhancement is funded by income raised from water and sewerage bills.

Where we provide or require assets that are designed to include an element of network enhancement, we will ensure that charges are apportioned such that we fund the network enhancement element. This apportionment will be based on assumed flow rates for the development in relation to that of the other flows allowed for in the design.

8.9 Interaction with the planning system

Our infrastructure charges will ensure that the cost of providing network reinforcement is met by new connection services' customers and we can plan and execute works required. This planning and execution of works should mean that local planning authorities will no longer require assurance that we can serve particular developments, as long as the development does not progress at a rate which exceeds the time we need to provide capacity. In some circumstances, we may need to agree a phasing condition from the planning authority to protect customers and/or the environment.

We have agreed to comply with guidelines developed by Water UK.

8.10 Frequently asked questions

Frequently asked questions	
What are infrastructure charges?	Infrastructure charges are one-off payments used to cover the cost of improving our networks (water and sewerage) to cope with providing extra capacity for new developments.

9. Our contact details

Email: developer.services@wessexwater.co.uk

Telephone: 01225 526 222 or 01225 526 333
Monday to Thursday, 8.30am to 4.30pm, Friday 8.30am to 4pm
To protect our customers and staff calls may be recorded

Write to: Developer Services
Wessex Water
Claverton Down
Bath, BA2 7WW

10. Our charges in full

Should you require help understanding your needs, please do not hesitate to contact us.

Table 3-1 Charges payable for asset plans and viability studies

Description	Unit pricing	Price
Extract of our network map (i.e. map of existing sewers or mains) – printed or sent electronically	Each	£15
Extract of company's network map (i.e. map of existing sewers or mains) – online access	Each	FREE
Pre-Planning Enquiry Response - to advise points of connection and/or discharge, capacity* and asset protection arrangements	per enquiry	FREE
Site Specific charge for the verification of Odour Modelling	per enquiry	£890

Table 3-2 Abortive and additional visit charges

Description	Unit pricing	Price
Any abortive site visit	per visit	£72 + any relevant costs
Additional site inspections	per visit	£151
If site is not ready, standing time for standard 3-man gang	per hour	£165
If site is not ready, abortive fees for standard 3-man gang	each visit	£2,516
If site is not ready, remobilisation charges for standard 3-man gang	as required	£1,258

Table 3-3 Traffic management & road closure charges

Description	Unit pricing	Price
Streetworks permits*	Per charges published at the time by Highway authority area and local council	On application or check the relevant website for information
Road closure - signage	Per closure	£543
Person in attendance for traffic management**	Per day	£286
Suspend / bag off pedestrian crossing	Per crossing	£488
Suspend / bag off traffic lights	Per job	£709
Temporary 2 way lights	Per job	£191
Temporary multiway lights	Per job	£233
Designated parking bay suspension	Per job	£188
Temporary pedestrian crossing system	Per job	£784
Electronic variable message sign	Per week	£557

* Permit fees are set locally by the highway authority and vary considerably. Therefore, the appropriate charges, consistent with those published at the time of your application, will be added to your quote.

** The "person in attendance" is provided by our traffic management provider and is fully trained/qualified to do this work.

As the highway regulations are controlled and managed by a third party (The local Highways Authority), it won't always be possible for us to include all applicable traffic management charges at the time of your quote. Where this is the case, you will be invoiced separately for any additional items, or refunded where items are no longer required, as applicable.

Table 4-1 Service connection administration charges (non-contestable) Section 45

Description	Unit pricing	Price
Administration and application fee where Wessex Water makes the connection (first connection)	per connection	£122
Administration and application fee where Wessex Water makes the connection (each subsequent connection)	per connection	£33
Administration fee where an Accredited Third Party makes the connection (first connection)	per connection	£40
Administration fee where an Accredited Third Party makes the connection (each subsequent connection)	per connection	£27
Trench inspections (where we inspect service pipes laid by others)	per trench	£45

Table 4-2 Service connection charges (contestable) Section 45

Description	Unit pricing	Price
Point of connection enquiry (where the customer has not selected the point of connection)	per enquiry	FREE
Design of service connection (where contestable)	per application	FREE
With Excavation by Wessex Water:		
* Connection (≤ 32 mm diameter) to main including supply and installation of meter & meter box & up to 2 linear metres of service pipe	per connection	£923
* Additional connection (≤ 32 mm diameter) - No Excavation required including supply and installation of meter and meter box	per connection	£215
* Connection (> 32 mm diameter) to main including supply and installation of meter & meter box & up to 2 linear metres of service pipe	per connection	£1,560
* Additional connection (> 32 mm diameter) - No Excavation required including supply and installation of meter and meter box	per connection	£863
Supply and lay additional communication pipe in Verge/Unmade Ground (reinstate where required)	per linear metre	£265
Supply and lay additional communication pipe in Footpath (reinstate where required)	per linear metre	£432
Supply and lay additional communication pipe in Road (reinstate where required)	per linear metre	£535
Manifold Connection by means of four port manifold (four connections) including up to 2 linear metres of communication pipe	per manifold	£1,856
Manifold Connection by means of six port manifold (six connections) including up to 2 linear metres of communication pipe	per manifold	£1,900
With Excavation by Others:		
* Connection (≤ 32 mm diameter) to main (including supply and installation of meter & meter box)	per connection	£271
* Additional connection (≤ 32 mm diameter) including supply and installation of meter and meter box	per connection	£215
* Connection (> 32 mm diameter) to main (including supply and installation of meter & meter box)	per connection	£948
* Additional connection (> 32 mm diameter) including supply and installation of meter and meter box	per connection	£863
Manifold Connection by means of four port manifold (four connections)	per manifold	£1,244
Manifold Connection by means of six port manifold (six connections)	per manifold	£1,288
Other Applicable Charges:		
Supply and lay additional communication pipe without excavation	per linear metre	£37
Supply 15mm meter (non-AMR)	per meter	£46
Supply 15mm meter (AMR)	per meter	£94
Install and commission meter and/or meter box - labour only, components not included (only for meter types that necessitate a non-contestable delivery)	per meter	£31
Connection charge for building water (if not metered)	per plot	£95
Traffic management fees		Table 3-3
Road closure fees		Table 3-3

* Connections are contestable unless the work would present heightened risk to existing assets or could affect supplies to existing customers. Our definition of heightened risk is set out and reviewed annually as part of the Contestability Summary. This can be found in the technical guidance documents [here](#).

Table 4-3 Disconnection charges (non-contestable) Section 62

Description	Unit pricing	Price
Permanent disconnection for domestic properties	each	FREE

Table 5-1 Providing a public main as a Section 41 requisition (non-contestable) Section 41

Description	Unit pricing	Price
Mains administration and application fee	per application	£95
Mains design checking fee (applied whether design is done by us or third party)	per requisition	£253
Mains connection for connecting 49 properties or less that involves heightened risk to existing assets or could affect supplies to existing customers	per connection	£4,375
Mains connection for connecting 50 properties or more that involves heightened risk to existing assets or could affect supplies to existing customers	per connection	£7,871
Laying of additional mains where required to connect to nearest water main		Table 5-2

Table 5-2 Providing a public main as a Section 41 requisition (contestable) Section 41

Description	Unit pricing	Price
Point of connection enquiry (where the customer has not selected the point of connection)	per enquiry	FREE
Mains design fee (excluding checking fee)	per requisition	£460
Re-design fee where layout subsequently amended	per request	£249
Excavation by Others - Supply and lay pipe	per linear metre	£87
Excavation by Wessex Water - Supply and lay additional pipe in Verge/Unmade Ground	per linear metre	£125
Excavation by Wessex Water - Supply and lay additional pipe in Footpath	per linear metre	£147
Excavation by Wessex Water - Supply and lay additional pipe in Road	per linear metre	£232
Land entry agreements including compensation and legal fees	per linear metre	£31
Providing a booster where a customer desires guaranteed pressure greater than 0.7 bar at any point on the site	per booster	£172,783
Routine in-line mains connections (second connection of main in case of diversion)	per connection	£652
Pressure testing	per test	£519
Chlorination	per phase	£370
Sampling and undertaking standard analysis	per sample	£187
Traffic management fees		Table 3-3
Road closure fees		Table 3-3

Table 5-3 Adopting self-laid mains (non-contestable) Section 51

Description	Unit pricing	Price
Pre-commencement fee	per application	FREE
Re-inspection fee	per site visit	FREE
Legal agreement fee (for new agreements or reassessments of previous assessments)	per adoption	FREE
Service connection administration fees (where an SLP is providing these)	per connection	Table 4-1
(Excavate), supply and lay pipe (and reinstate where required)		Table 5-1

Table 5-4 Adopting self-laid mains (contestable) Section 51

Description	Unit pricing	Price
Mains design fee (excluding checking fee)	per design request	£460
(Excavate), supply and lay pipe (and reinstate where required)		Table 5-2

Table 5-5 Diverting water mains (contestable and non-contestable) Section 185

Description	Unit pricing	Price
Administration and Application fee	per application	£173
Design fee (where a main is to be diverted) (refundable in part)	per design	£2,133
Technical assessment fee (where the design for the diversion is provided by the customer)	per assessment	£257
Inspection fee (where the diversion work is provided by the customer)	per inspection	£251
Disconnection/reconnection of main (shut off)	per connection	£1,279
Disconnection/reconnection of main (line stop)	per connection	£5,549
Decommissioning redundant communication pipe	per linear metre	£32
Reinstatement of ground for washout/slucice valve installation	each	£203
(Excavate), supply and lay pipe (and reinstate where required)		Tables 5-1 & 5-2

Table 6-1 Sewer connection charges (contestable and non-contestable) Section 106 & 107

Description	Unit pricing	Price
Administration, Application & technical approval fee	per application	£82
Connection by means of a Y-junction or saddle (including materials)	per connection	£441
Inspection of a connection via a manhole	per application	£116

Table 7-1 Providing a public sewer or lateral drain (non-contestable) Section 98

Description	Unit pricing	Price
Administration & Application fee	per application	£337
Point of connection enquiry (where the customer has not selected the point of connection)	per requisition	FREE

Table 7-2 Requisition charges for new public sewers (contestable) Section 98

Description	Unit pricing	Price
Gravity Sewer - Supply and lay ≤ 225mm diameter pipe at ≤ 3m depth - Excavation by Water Company (reinstate where required)		
In field	per linear metre	£1,929
In made ground		£2,131
In road		£2,289
Gravity Sewer - Supply and lay > 225mm & ≤ 300mm diameter pipe at ≤ 3m depth - Excavation by Water Company (reinstate where required)		
In field	per linear metre	£2,039
In made ground		£2,261
In road		£2,423
Pumped Sewer - Supply and lay 80mm diameter pipe at ≤ 1.5m depth - Excavation by Water Company (reinstate where required)		
In field	per linear metre	£1,279
In made ground		£1,346
In road		£1,556
Design & Installation of Sustainable Drainage Scheme (SuDS)	per scheme	Price on Application
Land entry agreements including compensation and legal fees	per linear metre	£31
Traffic management fees		Table 3-3
Road closure fees		Table 3-3
Decommissioning redundant pipe (if diverting a sewer under a section 185 diversion)	per linear metre	£32

Table 7-3 Adopting existing sewerage assets (non-contestable) Section 102

Description	Unit pricing	Price
Administration & Application fee	per application	£115
Technical approval	per application	£506
Inspection	per application	£488
Pumping Station compliance fee	per pumping station	£1,427
Land transfer fee	per agreement	£1,166
Pumping Station telemetry provision via cellular communications, as compliant with Design and Construction Guide (DCG) and Wessex Water's Associated Addendum	per installation	£2,928
Pumping Station telemetry provision for sites with no cellular communications and/or multiple inhibit links, as compliant with Design and Construction Guide (DCG) and Wessex Water's Associated Addendum	per installation	Price on Application
Excavate supply and lay pipe (and reinstate where required)		Table 7-2

Table 7-4 Adopting new sewerage assets (non-contestable) Section 104

Description	Unit pricing	Price
Administration & Application fee	per application	£145
Technical approval (Initial Submission)	per application	£539
Technical approval (Subsequent submissions)	per re-submission of application	£216
Adoption compliance fee - for our estimated construction cost <£50k	fixed cost (up to 2 inspections per month)	£1,191
Adoption compliance fee - for our estimated construction cost £50k - £100k	fixed cost (up to 2 inspections per month)	£2,857
Adoption compliance fee - for our estimated construction cost £100k -£1m	fixed cost (up to 2 inspections per month)	£4,525
Adoption compliance fee - for our estimated construction cost >£1m	fixed cost based on our estimated construction cost	0.40%
Legal agreement fee (for new agreements or reassessments of previous assessments)	per agreement or per adoption	£594
Surety or deposit (if appropriate) (refundable in part)	percentage of our estimated construction cost	10% or minimum of £5,000
SUDS Adoption compliance fee	per SUDS	Price on Application
Deed of grant fee	per agreement	£935
Pumping Station adoption compliance fee	per pumping station	£1,427
Land transfer fee	per agreement	£1,166
Pumping Station telemetry provision via cellular communications, as compliant with Design and Construction Guide (DCG) and Wessex Water's Associated Addendum	per installation	£2,928*
Pumping Station telemetry provision for sites with no cellular communications and/or multiple inhibit links, as compliant with Design and Construction Guide (DCG) and Wessex Water's Associated Addendum	per installation	Price on Application
Excavate supply and lay pipe (and reinstate where required)		Table 7-2

* This price is only applicable if telemetry is installed within 2 years of the date of application. Thereafter the price will be subject to the charging arrangements in place at the time of installation.

**Table 7-5 Diverting a public sewer asset – major or minor diversion (non-contestable)
Section 185**

Description	Unit pricing	Price
Administration & Application fee (includes letter of agreement)	per application	£123
Technical assessment fee (where the design for the diversion is provided by the customer)	per assessment	£334
Inspection fee (where the diversion work is provided by the customer)	per site	£465
Surety or deposit (if appropriate)	percentage of our estimated construction cost	10% or minimum of £500 for minor diversion, or minimum of £5,000 for major diversion
Appraisal fee (where we divert a critical or major sewer) (refundable in part)	per appraisal	£2,000
Pumping Station compliance fee (for option 2 diversions)	per pumping station	£1,427
Land transfer fee	per agreement	£1,166
Pumping Station telemetry provision via cellular communications, as compliant with Design and Construction Guide (DCG) and Wessex Water's Associated Addendum - only chargeable under option 2 diversions where developer builds pumping station	per installation	£2,928*
Pumping Station telemetry provision for sites with no cellular communications and/or multiple inhibit links, as compliant with Design and Construction Guide (DCG) and Wessex Water's Associated Addendum - only chargeable under option 2 diversions where developer builds pumping station	per installation	Price on Application
Excavate supply and lay pipe (and reinstate where required) or decommission redundant pipe		Table 7-2

* This price is only applicable if telemetry is installed within 2 years of the date of application. Thereafter the price will be subject to the charging arrangements in place at the time of installation.

Table 8-1 Water infrastructure charges Section 146

Description	Unit pricing	Price
Infrastructure credits to account for relevant use within the last five years	Number of credits	-£204
Infrastructure charges due for the development	Per dwelling	£204
Credit for sustainable development consuming <100lpppd	Per dwelling	-£100
Relevant multiplier charges due for the development	Charge based on fittings	RM x £204
Income offset	% reduction	65%

Table 8-2 Sewerage infrastructure charges Section 146

Description	Unit pricing	Price
Infrastructure credits to account for relevant use within the last five years	Number of credits	-£893 / -£447 / -£89
Infrastructure charge due for development (no surface water abatement)	Per dwelling	£893
Relevant multiplier due for the development	Charge based on fittings (calculated by reference to table 8-3)	RM x £893
Infrastructure charge for schemes with the inclusion of an agreed SuDS scheme that attenuates the flow of surface water into our existing or proposed network	Per dwelling	£447
Infrastructure charge for schemes that commit to zero surface water discharge into our existing or proposed network	Per dwelling	£89
Income offset	% reduction	16%

Table 8-3 Relevant multiplier loading units for non-standard properties

Water fitting/appliance	Loading units
WC flushing cistern	2
Urinal	3
Wash basin in a house	1.5
Wash basin elsewhere	3
Bath (tap nominal size 3/4"/20mm)	10
Bath tap nominal size > 3/4"/20mm)	22
Shower	3
Sink (tap nominal size 1/2"/15mm)	3
Sink (tap nominal size > 1/2"/15mm)	5
Spray tap	0.5
Bidet	1.5
Domestic appliance	3
Communal or commercial appliance	10
Any other waste fitting or outlet	3
Indoor swimming pool	24

Appendix A Glossary and defined common terms

Term	Definition
Abortive visit	Where a visit cannot be completed – for example where the site is unsafe, or the customer has not prepared the site ready for a connection to be made - a charge will be made for an abortive visit.
Additional site visit	Where additional visits need to be made, in line with our policy of cost-reflective charges, we will make a charge for that additional visit.
Accredited Third Party	A recognised organisation who, in respect of Contestable Work and Services, demonstrates competence, at all relevant times, by satisfying the following: (i) accreditation under WIRS; and/or (ii) the Water Company's local accreditation arrangements in relation to a specified activity. Contractors and multi-utility infrastructure providers laying mains for the developers (otherwise known as Self-Lay Providers).
Accredited provider	A contractor who holds a Wessex Water permit card.
Administration & Application fee	Fees at the point of application to recover costs reasonably incurred in administration required for processing the application and undertaking general administration such as processing payments, scheduling works, supervision and project management. This does not include site-based activities covered in construction costs.
Administration fee (first connection)	Administration costs include setting up the account etc. Additional costs may be incurred for the first connection.
Administration fee (subsequent properties)	Administration costs include setting up the account etc. Once the account is set up, the additional costs are generally lower.
Adoption	This is the process by which we take over responsibility for infrastructure such as mains and sewers which are subsequently maintained at our expense.
Adoption compliance fee	Charge for ensuring that adopted assets comply with the requisite standards.
Adoption of existing assets (s102)	Existing sewers and other assets may be adopted under section 102 of the Water Industry Act 1991.
Adoption of new sewers (s104)	New sewers and other assets may be adopted under section 104 of the Water Industry act 1991.
Alternative Point of Connection	Another location indicated by us which is neither i) a practical location indicated by the Developer Customer, nor ii) the nearest practical location where the existing Water Main or Sewer is the same size or larger than the new connecting Water Main or Sewer.
AMR meter	A meter fitted to allow automatic reading
Annual Contestability Summary	The standard format document published annually (or more frequently) by us on our website setting out which work and services are Contestable Work and Services and which are Non-contestable Work and Services as described in section 3 of the Water Sector Guidance (see www.water.org.uk/water-sector-guidance-approved-documents/).
Appraisal fee	Maximum charge for technical assessment and design of diversion proposals. A partial refund may be available.
Barrier Pipe	A polyethylene (PE) pipe with an aluminium barrier layer conforming to water industry specification 4-32-19.

Term	Definition
Booster	Device fitted to maintain adequate water pressure.
Brownfield site	A site that has previously been built upon (as opposed to a 'greenfield' site that has never been built upon).
Building water	Charge for water used during construction of property.
CCTV survey	Inspection of condition of a sewer by camera.
Charging arrangements	The document setting out the charges, income offset, and/or the methodologies for calculating those, applied by the water or sewerage undertaker in accordance with the Charging Rules issued by Ofwat.
Charging year	A calendar year running from 1 April in a given year to 31 March in the following year.
Chlorination	Disinfection of new water mains.
Commissioning	The process of filling the mains with water so that the supplies are available for customers to use. This will be after the necessary quality tests have taken place.
Communication pipe	Means any part of a Service Pipe which a Water Company could be, or have been, required to lay under section 46 of the Water Industry Act 1991. Typically, it consists of a pipe laid from an existing or newly laid Water Main to the boundary of a property and may include a meter housing and / or external stop valve.
Connection by means of a Y-junction or saddle	Method of connecting up to three properties to the sewerage system. This work is generally undertaken by Wessex Water under section 107.
Connection by means of manifold (four or six connections)	Means of connecting up to four properties to the water supply system. Excavate to expose existing main, tap and connect communication pipe, excavate and install manifold and surface box.
Connection charges	Charges to recover costs of connecting new developments to the water mains and/or public sewer systems.
Connection through an existing or new manhole	Method of connecting to the public sewerage system.
Connection to main including supply and installation of meter & meter box & up to 2 linear meters of service pipe	Excavate to expose existing main, tap and connect live main, excavate and lay communication pipe, excavate and install MVU/meter box.
Contaminated ground	Ground that requires protective barrier pipe to be installed.
Contestable work	The work or services that can be completed by either Wessex Water or an Accredited Third Party, with the work and services relating to the provision of water supplies defined the Annual Contestability Summary. For work related to new sewerage services, the majority of work is considered contestable, excluding diversions and requisitions.
Crop field	Field in which crops are being grown.
Design Checking Fee	Fee to cover the cost of checking a design, whether prepared by us or submitted by an Accredited Third Party.
Design fee	Charge for preparing scheme drawing. This excludes the cost for checking the design and is charged separately.
Developers	Those who organise the purchase of land, construction of new buildings and their sale.

Term	Definition
Development	Premises on which there are buildings, or on which there will be buildings when proposals made by any person for the erection of any buildings are carried out, and which require connection with, and/or modification of, existing water or sewerage infrastructure.
Decommissioning of redundant pipe	The abandoned pipe either needs to be broken out or in the case of a sewer, alternatively fully grouted up to prevent collapse, water or rodent ingress and render it no longer viable as a sewer.
Diversion charges	Charges to recover costs reasonably incurred in diverting mains or public sewers.
Domestic Purposes	Water used in any premises for drinking, washing, cooking, central heating and sanitary purposes. (Water Industry Act s218)
Domestic fire sprinkler connection	Provide un-metered connection for fire sprinkler purposes.
Excavation by Others	means any work undertaken by someone other than the Water Company in excavation, backfilling or reinstatement.
Excavation by Wessex Water	means any work undertaken by the Wessex Water (or an agent acting on our behalf) in excavation, backfilling or reinstatement.
Existing mains/existing network	The parts of the system commissioned independently of development commencing. These will include off-site and on-site pipework, some of which may supply existing customers.
Extension to the network	A single pipe that is laid from the existing network to serve new customers.
Extract of our network map	Provide extract of network layout to customer's requirements – printed, sent electronically or via online access.
Field	An area of open land normally bounded by hedges or fences
Fixed charges	Charges set for a given charging year which are fixed in amount or which are calculated by reference to a predetermined methodology set out in the undertaker's charging arrangements, the application of which allows calculation at the outset of the total amount owing in that charging year in respect of the charges in question. Such charges are to be fixed for a charging year, as defined above.
Footpath	A hard-surfaced area intended for use by pedestrian or cyclists.
Four port manifold	A manifold which is used to connect four new connections to our network.
Highway	Vehicle access way
Household premises	Any premises used principally as a domestic dwelling or intended for such use, such as a house or flat.
Income offset	A sum of money offset against the charges that would otherwise be applied for the provision of a sewer or water main in recognition of revenue likely to be received by the relevant undertaker in future years for the provision of: (i) supplies of water to premises connected to the new water main; or (ii) sewerage services to premises connected to the new sewer, and 'income offsetting' shall be construed accordingly. From April 2020, the income offset will be applied to the infrastructure charge. From April 2025, income offset will no longer be applied to our charges.
Infrastructure charge	The charges described in section 146(2) of the Water Industry Act 1991. That is, a charge paid by the Developer Customer to us when a property

Term	Definition
	is connected to the company's water supply or sewer network for the first time. The charges fund wider network reinforcement throughout the region to meet the increased demand arising from the new connections.
Infrastructure credit	Discount applied where a development has previously been connected to our network within the previous five years. The credit should be applied by deducting the number of former houses connected on the site or by taking the metered consumption or discharge from the site and equating to that of an average house within our area to arrive at an equivalent number of houses. In the absence of metered information other reasonable evidence should be used to estimate the prior demand on the network from the site.
Inspection fees	Charge for inspection of site.
Install and commission meter and/or meter box	Excavate and install meter and meter box
Land entry costs	Payment made to landowner to gain access
Lateral drain	(a) that part of a drain which runs from the curtilage of a building (or buildings or yards within the same curtilage) to the sewer with which the drain communicates or is to communicate; or (b) (if different and the context so requires) the part of a drain identified in a declaration of vesting made under section 102 of the Water Industry Act 1991 above or in an agreement made under section 104 of this Act.
Legal fees	Charge for professional legal services
Live main	A main connected to the water network and filled with water.
Mains administration fee	Charge to recover costs reasonably incurred in administration connected to s41 requisition.
Mains design approval	Our cost for reviewing and approving mains designed by others.
Mains design fee	Design of distribution mains layouts to serve site specific requirements.
Network reinforcement	Modifications necessary to an existing network in order to provide the required water to a new development without compromising existing levels of service to existing customers. Network reinforcement can include such things as mains reinforcement/upsizing, booster station and service reservoir construction etc.
New appointment or variation (NAV)	A company appointed by Ofwat through the new appointments and variations process to provide water and/or sewerage services to customers in an area previously served by the incumbent Water Company. A new appointment is made when Ofwat appoints a company for the first time to provide services for specific geographic area. A variation occurs where an existing appointment is varied to amend the area served.
New main	A main laid by the developer (or its contractor/SLP) as part of a development.
Non-contestable	Not open to competition.
Non-contestable work	Work or services that can only be completed by the Wessex Water (or an agent acting on our behalf) and, in the case of work or services associated with the provision of water supplies, is defined in the Annual Contestability Summary.

Term	Definition
Non-domestic purposes	Water used primarily for non-domestic purposes, including anything not for Domestic Purposes, such as water for industrial or business use (including manufacturing processes, washing and cleaning and cooling), agricultural use and filling swimming pools.
Off-site	In the public highway or in land owned by people other than the developers.
On-site (may be termed site specific)	Land owned by developers.
Permanent disconnection	Water supply removed from premises
Point of connection enquiry	Identification of suitable location for development to connect to supply or sewerage network
Pre-commencement fee	Fee to instigate internal design works, enable preliminary inspections and liaison with developer
Pressure testing	Testing to make sure that the new mains have been constructed and joined correctly and that they will carry the working pressure required.
Providing and/or commissioning company specific telemetry for assets offered for adoption	To provide remote monitoring (telemetry) of the status and performance of sewage pumping station assets. Remote monitoring of these assets allows failures to be rapidly detected, and maintenance/operational staff to be deployed as necessary.
Public sewer	A sewer for the time being vested in a sewerage undertaker, whether under the Water Act 1989, the Water Industry Act 1991 or otherwise.
Re-design fee where layout subsequently amended	Reduced fee where part of design work has been carried out
Re-inspection fee	Re-inspection of works following amendments, alterations and corrections to agreed works
Reinstatement	Work carried out to restore the surface of the ground to its original condition; for example, resurfacing a road after work to lay water mains.
Relevant multiplier	Multiplier that takes account of developments other than houses where the number of water fittings may deviate from an average house
Remobilisation charges	Charge for additional work required to revisit site
Requisition	We must provide water mains that are sufficient for domestic purposes when required to do so by a notice under sections 41 to 44 of the Water Industry Act 1991. This is known as a requisition. We must provide the mains once the financial conditions of compliance are satisfied and we have agreed the places for connecting the new pipes to its existing main or network.
Requisition charges	Charges to recover costs reasonably incurred in undertaking requisitions.
Returnable cash deposit/bond	Money refunded to customer on satisfactory completion of works
Rising main	Sewer that leaves a pumping station and is under pressure
Road	A hard-surfaced area intended for vehicles.
Road closure fees	Charge made by Highway Authority for closing public highway
Routine in-line mains connections	Piece through like-for-like diameter main to stop end valve in excavation opened by others.

Term	Definition
Safety at Street Works and Road Works (A Code of Practice) Red Book	This Code is directed at operatives, supervisors, managers, planners and designers who are responsible for making sure that all street and road works are safe for both operatives and the public.
Sampling and undertaking standard analysis	Taking a sample and analysing it to test for quality for DWTS (Drinking Water Testing Specification)
Security Surety or deposit	Percentage of the value of the works paid to us to provide a security to guard against incomplete or unsatisfactory works or remedial works required. If the works are completed to a satisfactory standard, this security is repaid and therefore acts as a deposit.
Self-lay	Where developers, or their contractors, install new water mains and service pipes instead of asking us to do the work.
Self-lay providers (SLPs)	Contractors and multi-utility infrastructure providers laying mains for the developers.
Service pipe	A pipe, which is, or is to be, connected with a Water Main for supplying water from that main to any premise.
Sewage pumping station	Design and Construction Guidance classifies pumping stations in the following way: Type 1 – having an incoming peak design flow of ≤ 0.25 litres per second (typically five dwellings or less) Type 2 – having an incoming peak design flow of > 0.25 litres per second but less than 1 litre per second (typically six to twenty dwellings). Type 3 – having an incoming peak design flow rate of ≥ 1 litre per second (typically more than twenty dwellings) but with pumps rated no more than 30 kW
Sewer	Includes all sewers and drains (not being drains within the meaning given by section 219(1) of the Water Industry Act which are used for the drainage of buildings and yards appurtenant to buildings. This definition includes tunnels or conduits which serve as such a pipe and any accessories for such a pipe.
Significant Variation	Changes to the design or construction of Self-Lay Works (including those due to site conditions, changes to the site made by the developer, etc.) which require the re-issue of either the SLP Accepted Design or the Water Company Design.
Site specific	Work on, or the provision of, water or sewerage structures or facilities located on a development as well as work to provide and connect a requested water main, sewer, communication pipe or lateral drain on, to or in the immediate vicinity of, the development and ‘site specific work” shall be construed accordingly. It does not refer to costs or work required as part of network reinforcement as defined above.
Site visit to plan the connection if necessary	Meeting on site to agree connection works
Six port manifold	A manifold which is used to connect six new connections to our network.
Standard infrastructure charge	Standard charge for a new property
Standing time	Time spent waiting for the customer to make the site ready.
Suitable contractor	A contractor who holds a Wessex Water permit card

Term	Definition
Supply and fit leakage monitoring meter	Installation of a meter on a new development to record flow to assist in leak detection activities. Where it is our decision to install this, we do not pass on our costs to customers.
Supply and lay additional pipe	Charge for laying pipe additional to that included in the basic connection cost.
Supply meter	Undertaker will provide meter body and meter box components for assembly by others
Supply pipe	The part of the Service Pipe that is not the Communication Pipe, and which remains the customer's responsibility. That part of the service pipe owned by the property owner.
Technical approval	Review submission to ensure compliance our requirements/Design and Construction Guidance.
Technical assessment fee	Charge for review of diversion plans
The Water Supply (Water Fittings) Regulations 1999	These Regulations are requirements for the prevention of contamination of water supplied, and it is our statutory duty to enforce them.
The Water Supply (Water Quality) Regulations 2000 and any subsequent amendments	These Regulations specify the standards used to define the wholesomeness of drinking water and also specify, under Regulation 31, the requirements for using approved substances and products. The DWI enforces the Regulations.
Trench inspections	Where supply pipe is inspected to ensure compliance with undertakers' standards
Trial hole	An exploratory excavation to identify the location of apparatus, prior to works commencing.
Undertaker	A water undertaker or sewerage undertaker.
Unmade Ground	Ground which does not have a man-made surface, and may feature grass and topsoil.
Upsizing mains	When we decide to lay a larger main than is needed to supply a new development. This might be because we consider that the demand for water will increase in the future and it is deemed Network Reinforcement.
Verge	Unmade ground.
Viability study, to confirm whether capacity can be provided by us in line with the proposed development programme	Investigation carried out on water and sewerage network to confirm point of connection to networks or if off-site reinforcement is required
Water efficiency multiplier	Multiplier to reflect water conservation measures a new connection services' customer may install or contribute to in order to reduce the development's impact on our network.
Water main	Any pipe, not being a pipe for the time being, vested in a person other than the undertaker, which is used or to be used by a water undertaker or licensed water supplier for the purpose of making a general supply of water available to customers or potential customers of the undertaker or water supply licensee, as distinct from for the purpose of providing a supply to particular customers. This definition includes tunnels or conduits which serve as a pipe and any accessories for the pipe.

Term	Definition
Water Supply Licensee (WSL)	Water supply and sewerage licensees (often known as retailers) have a licence to supply eligible business, charity and public sector customers mainly in England with retail services.

Appendix B Prescribed Worked Examples

In all our scenarios, it is worth noting that:

- We do not have separate costs for using barrier pipes. Our charges reflect the average charges whether PE or barrier pipe. Our policy is that all service connections use barrier pipe.
- We do not have separate costs for Administration and Application. We charge one combined fee.
- We include costs of a meter and its installation in our connection charge.
- Wastewater connection costs are not included as, in most cases, this work is not undertaken by Wessex Water. However, we reserve the right to make the connection ourselves under S107 and different charges would therefore be applicable.

Scenario 1 - Single connection to a house from an existing main

This worked example provides charges for a single connection to an existing water main of 90mm diameter polyethylene (PE). The worked example includes the associated charges for a single property connection to an existing sewer, which is completed by the customer. These charges are specified under 'Other Charges'.

Within construction costs, this includes: Service pipe installation; Boundary box fitting; Meter installation; Excavation; Reinstatement
Pipework:

- 25 – 32mm diameter PE pipe
- 4m pipework in road

Traffic management assumes the road (Type 3-4) is 40mph, has two lanes and does not require a road closure or lane closure. Two-way automated lights are required. There is also an assumption that the only payable council charges are for permitting. We have included in the example the average cost for our region. A customer will pay the charges applicable to their site and location.

Scenario 1: Single connection to a house from an existing main								Alternative Delivery Method ¹	
Applicable Charge?	Item	Unit	Qty	Rate (£)	Total Charge (£)	Barrier Pipe Total Charge (£) ²	Contestable ? (Y/N)	Self-Lay Rate (£)	Self-Lay Total Charge (£)
Pre-Construction Charges									
Y	Application Fee ³	per application	1	£122	£122	£122	N	£40	£40
N	Administration Fee	per application	N/A	N/A		N/A			
N	Design Fee	per application	N/A	N/A		N/A			
Construction Charges									
Y	Connection ⁴	per connection	1	£923	£923	£923	Y		
Y	Pipework - Road	per metre	2	£535	£1,070	£1,070	Y		
Y	Traffic Management permit ⁵	per TM usage	1	£58	£58	£58	Y		
Y	Temporary 2 Way Lights	per set of lights	1	£191	£191	£191	Y		
N	Meters	per connection	N/A	N/A		N/A			
Other Charges									
Y	Trench inspections ⁶	per trench	1	£45	£45	£45	N		
Y	Waste Connection Administration, Application & technical approval fee	per application	1	£82	£82	£82	N	£82	£82
Y	Inspection of waste connection via a manhole ⁷	per application	1	£116	£116	£116	N	£116	£116
Infrastructure Charges									
Y	Infrastructure Charge - Water	per property	1	£204	£204	£204	N	£204	£204
Y	Infrastructure Charges - Sewerage ⁸	per property	1	£447	£447	£447	N	£447	£447
Income Offset									
Y	Income Offset - Water	per property	1	-£133	-£133	-£133	N	-£133	-£133
Y	Income Offset - Sewerage	per property	1	-£72	-£72	-£72	N	-£72	-£72
TOTALS					£3,054	£3,054			£685

¹ Charges for Alternative Delivery Method are in addition to those charges the SLP imposes on the customer

² Our charges reflect the average costs whether PE or barrier pipe is used

³ Our Application and Administration fee is combined as one charge.

⁴ Meter is included in our service connection rates.

⁵ This is the average cost for our region. A customer will pay the permit cost specific to their site location

⁶ Self certification for WIRS Accredited SLPs so Trench inspection charge not required for SLP or NAV customers.

⁷ We reserve the right to make the connection ourselves under S107 and different charges would be applicable.

⁸ In most single developments, it is expected that there is some attenuation of the flow of surface water and therefore our mid-charge, included above, applies. However there may be occasional circumstances where the higher charge will be applicable.

Scenario 2 - Single connection to a block of flats from an existing main

This worked example provides charges for a block of 10 flats to be connected to an existing main of 90mm diameter PE. Each flat will be individually metered. The worked example should include the associated charges for connection to an existing sewer, which is completed by the customer.

Within construction costs, this includes: Service pipe installation; Boundary box fitting; Meter installation; Excavation; Reinstatement

Pipework:

- 63mm diameter PE pipe
- 4m pipework in road, 4m pipework in unmade ground

Traffic management assumes the road (Type 3-4) is 40mph, has two lanes and does not require a road closure or lane closure. Two-way automated lights are required. There is also an assumption that the only payable council charges are for permitting. We have included in the example the average cost for our region. A customer will pay the charges applicable to their site and location.

Our scenario assumes a requirement for an internal manifold which the customer is responsible for sourcing and installing. Another option available would be to use a 6 & 4 port manifold externally and appropriate charges would apply for this installation.

Scenario 2: Single connection to a block of flats from an existing main										Alternative Delivery Method ¹			
Applicable Charge?	Item	Unit	Qty	Rate (£)	Total Charge (£)	Barrier Pipe Uplift /Rate ²	Barrier Pipe Total Charge (£)	Contestable (Y/N)?	Self-Lay Rate (£)	Self-Lay Total Charge (£)	NAV Rate (£)	NAV Total Charge ³ (£)	
Pre-Construction Charges													
Y	Application Fee ⁴	per application	1	£122	£122	N/A	£122	N	£40	£40			
Y	Administration Fee ⁵	per application	9	£33	£297	N/A	£297	N	£27	£243			
N	Design Fee	per application	N/A	N/A		N/A							
Construction Charges													
Y	Connection ⁶	per connection	1	£1,560	£1,560	N/A	£1,560	Y					
Y	Pipework - Verge	per metre	4	£265	£1,060	N/A	£1,060	Y					
Y	Pipework - Road	per metre	2	£535	£1,070	N/A	£1,070	Y					
Y	Traffic Management permit ⁷	per TM usage	1	£58	£58	N/A	£58	Y					
Y	Temporary 2 Way Lights	per set of lights	1	£191	£191	N/A	£191	Y					
Y	Meters	per connection	9	£94	£846	N/A	£846	Y					
Other Charges													
Y	Trench inspections ⁸	per trench	1	£45	£45	N/A	£45	N					
Y	Waste Connection Administration, Application & technical approval fee	per application	1	£82	£82	N/A	£82	N	£82	£82	£82	£82	
Y	Inspection of waste connection via a manhole ⁹	per application	1	£116	£116	N/A	£116	N	£116	£116	£116	£116	
Infrastructure Charges													
Y	Infrastructure Charge - Water	per property	10	£204	£2,040	N/A	£2,040	N	£204	£2,040	£204	£2,040	
Y	Infrastructure Charges - Sewerage ¹⁰	per property	10	£89	£890	N/A	£890	N	£89	£890	£89	£890	
Income Offset													
Y	Income Offset - Water	per property	1	-£133	-£1,326	N/A	-£1,326	N	-£133	-£1,326	-£133	-£1,326	
Y	Income Offset - Sewerage	per property	1	-£14	-£142	N/A	-£142	N	-£14	-£142	-£14	-£142	
TOTALS					£6,909	£0	£6,909			£1,943		£1,660	

¹ Charges for Alternative Delivery Method are in addition to those charges the SLP/NAV imposes on the customer

² Our charges reflect the average costs whether PE or barrier pipe is used

³ A scenario of a NAV alternative delivery method is unlikely for a single connection to a block of flats.

⁴ Our Application and Administration fee is combined as one charge

⁵ This is our application and administration fees for each subsequent connection to the first connection above.

⁶ Alternative connections by external manifolds are available at separate costs

⁷ This is the average cost for our region. A customer will pay the permit cost specific to their site location

⁸ Self certification for WIRS Accredited SLPs so Trench inspection charge not required for SLP or NAV customers

⁹ We reserve the right to make the connection ourselves under S107 and different charges would be applicable

¹⁰ In most flats developments, the minimum charge is applicable. However there may be occasional circumstances where higher charges will be applicable.

Scenario 3: Medium housing development requiring new mains and communication pipes (excavation and reinstatement by others)

This worked example provides charges associated with the provision of new water mains and individual connections from them for each of 50 new houses. The worked example includes the associated charges for the 50 property connections to an existing sewer, which are completed by the customer. This worked example assumes excavation and reinstatement activities are completed by others, except for the excavation leading to the connection to the existing water main.

Within construction costs, this includes: Mains laying; Service pipe installation; Boundary box fitting; Meter installation

Technical Specification (Connection) - Pipework (no excavation):

- Connection to Existing Main of 180mm diameter PE
- 3m pipework laying (per communication pipe)

Technical Specification (Mains) - Pipework: Total length 300m, consisting of:

- 125mm diameter PE – 10m road type 3-4 road (leading to the point of connection to an existing water main)
- 125mm diameter PE – 190m
- 90mm diameter PE – 100m

Design Considerations:

- 180mm diameter existing main, serving 150 existing customers
- Three commissioning phases
- Three sample chlorination and connections – footpath
- Four washouts - unmade ground
- Five valves (1 x 150mm, 3 x 100mm, 1 x 80mm) - unmade ground
- One trial hole - unmade ground

Traffic management assumes the road (Type 3-4) is 50mph, has two lanes and requires a road closure and eight parking pay suspensions. Any additional council charges for permitting should be included. We have included in the example the average cost for our region. A customer will pay the charges applicable to their site and location.

Scenario 3: Medium housing development requiring new mains and communication pipe (excavation and reinstatement by others)									Alternative Delivery Method ¹			
Applicable Charge?	Item	Unit	Qty	Rate (£)	Total Charge (£)	Barrier Pipe Uplift /Rate ²	Barrier Pipe Total Charge (£)	Conte stable (Y/N)?	Self-Lay Rate (£)	Self-Lay Total Charge (£)	NAV Rate (£)	NAV Total Charge (£)
Pre-Construction Charges - connection												
Y	Application Fee ³	per application	1	£122	£122	N/A	£122	N	£40	£40		
Y	Administration Fee ⁴	per application	49	£33	£1,617	N/A	£1,617	N	£27	£1,323		
N	Design Fee	per application	N/A	N/A		N/A						
Pre-Construction Charges - mains												
Y	Application Fee	per application	1	£95	£95	N/A	£95	N	£95	£95	£95	£95
Y	Administration Fee	per application	N/A	N/A		N/A						
Y	Design Fee	per application	1	£460	£460	N/A	£460	Y	£460	£460		
Construction Charges - connection												
Y	Service connection	per connection	50	£271	£13,550	N/A	£13,550	Y				
Y	Pipework ⁵	per metre	150	£37	£5,550	N/A	£5,550	Y				
N	Meter Installation ⁶	per meter	N/A	N/A		N/A						
Construction Charges - mains												
Y	Mains connection	per connection	1	£7,871	£7,871	N/A	£7,871	N	£7,871	£7,871	£7,871	£7,871
Y	Supply and lay additional pipe in Road	per metre	10	£232	£2,320	N/A	£2,320	Y	£232	£2,320		
Y	Routine in-line mains connections	per connection	3	£652	£1,956	N/A	£1,956	Y				
Y	Pipework	per metre	290	£87	£25,230	N/A	£25,230	Y				
Y	Road closure permits ⁷	per road closure	1	£1,124	£1,124	N/A	£1,124	Y	£1,124	£1,124		
Y	Road closure - signage	per road closure	1	£543	£543	N/A	£543	Y	£543	£543		
Y	Designated Parking bay suspension	per road closure	1	£188	£188	N/A	£188	Y	£188	£188		
Other Charges												
Y	Mains Design approval fee	per requisition	1	£253	£253	N/A	£253	N	£253	£253	£253	£253
Y	Mains Pressure testing	per test	3	£519	£1,557	N/A	£1,557	Y				
Y	Mains Chlorination	per phase	3	£370	£1,110	N/A	£1,110	Y				
Y	Mains Sampling and undertaking standard analysis	per sample	3	£187	£561	N/A	£561	Y				
Y	Waste Connection Admin, App & technical approval fee	per application	1	£82	£82	N/A	£82	N	£82	£82	£82	£82
Y	Inspection of waste connection via a manhole ⁸	per application	1	£116	£116	N/A	£116	N	£116	£116	£116	£116
Infrastructure Charges												
Y	Infrastructure Charge - Water	per property	50	£204	£10,200	N/A	£10,200	N	£204	£10,200	£204	£10,200
Y	Infrastructure Charges - Sewerage ⁹	per property	50	£89	£4,450	N/A	£4,450	N	£89	£4,450	£89	£4,450
Income Offset												
Y	Income Offset - Water	per property	1	-£133	-£6,630	N/A	-£6,630	N	-£133	-£6,630	-£133	-£6,630
Y	Income Offset - Sewerage	per property	1	-£14	-£712	N/A	-£712	N	-£14	-£712	-£14	-£712
TOTALS					£71,613		£71,613			£21,723		£15,725

¹ Charges for Alternative Delivery Method are in addition to those charges the SLP/NAV imposes on the customer

² Our charges reflect the average costs whether PE or barrier pipe is used

³ Our Application and Administration fee is combined as one charge

⁴ This is our application and administration fees for each subsequent connection to the first connection above.

⁵ This pipework charge is for unmade ground. Our connection charge includes an average charge which covers the 2m in footpath.

⁶ Meter installation is included in our service connection rates

⁷ We have included in the example the average cost for our region. A customer will pay the charge applicable to their site location.

⁸ We reserve the right to make the connection ourselves under S107 and different charges would be applicable

⁹ In most medium developments, the minimum charge is applicable. However there may be occasional circumstances where higher charges will be applicable.

Scenario 4: Medium housing development requiring new mains and communication pipes (excavation and reinstatement by Wessex Water)

This worked example provides charges associated with the provision of new water mains and individual connections from them for each of 50 new houses. The worked example includes the associated charges for the 50 property connections to an existing sewer, which are completed by the customer. This worked example assumes that the excavation and reinstatement activities are completed by Wessex Water. However, should the Developer appoint an SLP or NAV, this worked example assumes these (and other contestable items) would be carried out by the SLP or NAV.

Within construction costs, this includes: Mains laying; Service pipe installation; Boundary box fitting; Meter installation; Excavation; Reinstatement

Technical Specification (Connection) - Pipework (unmade ground):

- Connection to existing main of 180mm diameter PE
- 3m pipe laying (per communication pipe)

Technical Specification (Mains) - Pipework: Total length 300m, consisting of:

- 125mm diameter PE – 10m pipework in road (including connection to existing 180mm PE Main)
- 125mm diameter PE – 50m pipework in footpath
- 125mm diameter PE – 140m pipework in Unmade ground
- 90mm diameter PE – 100m pipework Unmade ground

Design Considerations:

- 180mm diameter existing main, serving 150 existing customers
- Three commissioning phases
- Three sample chlorination and connections - footpath
- Four washouts - unmade ground
- Five valves (1 x 150mm, 3 x 100mm, 1 x 80mm) - unmade ground
- One trial hole - unmade ground

Traffic management assumes the road (Type 3-4) is 50mph, has two lanes and requires a road closure and eight parking pay suspensions. Any additional council charges for permitting should be included. We have included in the example the average cost for our region. A customer will pay the charges applicable to their site and location.

We have further made the assumption that the developer lays new shared drainage with a single existing sewer.

Scenario 4: Medium housing development requiring new mains and communication pipe (excavation and reinstatement by Water Company)									Alternative Delivery Method ¹			
Applicable Charge?	Item	Unit	Qty	Rate (£)	Total Charge (£)	Barrier Pipe Uplift /Rate ²	Barrier Pipe Total Charge (£)	Contest able? (Y/N)	Self-Lay Rate (£)	Self-Lay Total Charge (£)	NAV Rate (£)	NAV Total Charge (£)
Pre-Construction Charges - connection												
Y	Application Fee ³	per application	1	£122	£122	N/A	£122	N	£40	£40		
Y	Administration Fee ⁴	per application	49	£33	£1,617	N/A	£1,617	N	£27	£1,323		
N	Design Fee	per application	N/A	N/A		N/A						
Pre-Construction Charges - mains												
Y	Application Fee	per application	1	£95	£95	N/A	£95	N	£95	£95	£95	£95
N	Administration Fee	per application	N/A	N/A		N/A						
Y	Design Fee	per application	1	£460	£460	N/A	£460	Y	£460	£460		
Construction Charges - connection												
Y	Service connection	per connection	50	£923	£46,150	N/A	£46,150	Y				
Y	Pipework ⁵	per metre	50	£265	£13,250	N/A	£13,250	Y				
N	Meter Installation ⁶	per meter	N/A	N/A		N/A						
Construction Charges - mains												
Y	Mains connection	per connection	1	£7,871	£7,871	N/A	£7,871	N	£7,871	£7,871	£7,871	£7,871
Y	Routine in-line mains connections	per connection	3	£652	£1,956	N/A	£1,956	Y				
Y	Pipework - unmade	per metre	240	£125	£30,000	N/A	£30,000	Y				
Y	Pipework - footpath	per metre	50	£147	£7,350	N/A	£7,350	Y				
Y	Pipework - road	per metre	10	£232	£2,320	N/A	£2,320	Y	£232	£2,320		
Y	Road closure permits ⁷	per road closure	1	£1,124	£1,124	N/A	£1,124	Y	£1,124	£1,124		
Y	Road closure - signage	per road closure	1	£543	£543	N/A	£543	Y	£543	£543		
Y	Designated Parking bay suspension	per road closure	1	£188	£188	N/A	£188	Y	£188	£188		
Other Charges												
Y	Mains Design approval fee	per requisition	1	£253	£253	N/A	£253	N	£253	£253	£253	£253
Y	Mains Pressure testing	per test	3	£519	£1,557	N/A	£1,557	Y				
Y	Mains Chlorination	per phase	3	£370	£1,110	N/A	£1,110	Y				
Y	Mains Sampling and undertaking standard analysis	per sample	3	£187	£561	N/A	£561	Y				
Y	Waste Connection Admin, App & technical approval fee	per application	1	£82	£82	N/A	£82	N	£82	£82	£82	£82
Y	Inspection of waste connection via a manhole ⁸	per application	1	£116	£116	N/A	£116	N	£116	£116	£116	£116
Infrastructure Charges												
Y	Infrastructure Charge - Water	per property	50	£204	£10,200	N/A	£10,200	N	£204	£10,200	£204	£10,200
Y	Infrastructure Charges - Sewerage ⁹	per property	50	£89	£4,450	N/A	£4,450	N	£89	£4,450	£89	£4,450
Income Offset												
Y	Income Offset - Water	per property	1	-£133	-£6,630	N/A	-£6,630	N	-£133	-£6,630	-£133	-£6,630
Y	Income Offset - Sewerage	per property	1	-£14	-£712	N/A	-£712	N	-£14	-£712	-£14	-£712
TOTALS					£124,033		£124,033			£21,723		£15,725

¹ Charges for Alternative Delivery Method are in addition to those charges the SLP/NAV imposes on the customer

² Our charges reflect the average costs whether PE or barrier pipe is used

³ Our Application and Administration fee is combined as one charge

⁴ This is our application and administration fees for each subsequent connection to the first connection above

⁵ This pipework charge is for unmade ground. Our connection charge includes an average charge which covers the 2m in footpath

⁶ Meter installation is included in our service connection rates

⁷ We have included the average cost for our region. A customer will pay the charge applicable to their site location.

⁸ We reserve the right to make the connection ourselves under S107 and different charges would be applicable

⁹ In most medium developments, the minimum charge is applicable. However there may be occasional circumstances where higher charges will be applicable.

Scenario 5: Large housing development requiring new mains and communication pipes (excavation and reinstatement completed by others)

This worked example provides charges associated with the provision of new water mains and individual connections from them for each of 200 new houses. The worked example includes the associated charges for the 200 property connections to an existing sewer, which are completed by the customer. This worked examples assumes excavation and reinstatement activities are completed by others, except for the excavation leading to the point of connection to the existing water main.

Within construction costs, this includes: Mains laying; Service pipe installation; Boundary box fitting; Meter installation

Technical Specification (Connection) - Pipework (no excavation):

- Connection to existing main of 180mm diameter PE
- 3m pipe laying (per communication pipe)

Technical Specification (Mains) - Pipework: Total length 1000m, consisting of:

- 180mm diameter PE – 20m pipework in type 3-4 road (leading to point of connection)
- 180mm diameter PE – 100m pipework
- 125mm diameter PE – 480m pipework
- 90mm diameter PE – 400m pipework

Design Considerations:

- 250mm diameter existing main, serving 150 existing customers
- Six commissioning phases
- Six sample chlorination and connections - footpath
- Ten washouts – unmade ground
- Eight valves (1 x 150mm, 5 x 100mm, 2 x 80mm) - unmade ground
- Two trial holes - unmade ground

Traffic management assumes the road (Type 3-4) is 50mph, has two lanes and requires a road closure and eight parking pay suspensions. Any additional council charges for permitting should be included. We have included in the example the average cost for our region. A customer will pay the charges applicable to their site and location.

We have further made the assumption that the developer lays new shared drainage with a single existing sewer.

Scenario 5: Large housing development requiring new mains and communication pipe (excavation and reinstatement by others)										Alternative Delivery Method ¹		
Applicable Charge?	Item	Unit	Qty	Rate (£)	Total Charge (£)	Barrier Pipe Uplift /Rate	Barrier Pipe Total Charge (£) ²	Contest able (Y/N)?	Self-Lay Rate (£)	Self-Lay Total Charge (£)	NAV Rate (£)	NAV Total Charge (£)
Pre-Construction Charges - connection												
Y	Application Fee ³	per application	1	£122	£122	N/A	£122	N	£40	£40		
Y	Administration Fee ⁴	per application	199	£33	£6,567	N/A	£6,567	N	£27	£5,373		
N	Design Fee	per application	N/A	N/A		N/A						
Pre-Construction Charges - mains												
Y	Application Fee	per application	1	£95	£95	N/A	£95	N	£95	£95	£95	£95
N	Administration Fee	per application	N/A	N/A		N/A						
N	Design Fee	per application	1	£460	£460	N/A	£460	Y	£460	£460		
Construction Charges - connection												
Y	Service connection	per connection	200	£271	£54,200	N/A	£51,400	Y				
Y	Pipework ⁵	per metre	600	£37	£22,200	N/A	£22,200	Y				
N	Meter Installation ⁶	per meter	N/A	N/A		N/A						
Construction Charges - mains												
Y	Mains connection	per connection	1	£7,871	£7,871	N/A	£7,871	N	£7,871	£7,871	£7,871	£7,871
Y	Supply and lay additional pipe in Road	per metre	20	£232	£4,640	N/A	£4,640	Y	£232	£4,640		
Y	Routine in-line mains connections	per connection	6	£652	£3,912	N/A	£3,912	Y				
Y	Pipework	per metre	980	£87	£85,260	N/A	£85,260	Y				
Y	Road closure permits ⁷	per road closure	1	£1,149	£1,149	N/A	£1,149	Y	£1,149	£1,149		
Y	Road closure - signage	per road closure	1	£543	£543	N/A	£543	Y	£543	£543		
Y	Designated Parking bay suspension	per road closure	1	£188	£188	N/A	£188	Y	£188	£188		
Other Charges												
Y	Mains Design approval fee	per requisition	1	£253	£253	N/A	£253	N	£253	£253	£253	£253
Y	Mains Pressure testing	per test	6	£519	£3,114	N/A	£3,114	Y				
Y	Mains Chlorination	per phase	6	£370	£2,220	N/A	£2,220	Y				
Y	Mains Sampling and undertaking standard analysis	per sample	6	£187	£1,122	N/A	£1,122	Y				
Y	Waste Connection Admin, App & technical approval fee	per application	1	£82	£82	N/A	£82	N	£82	£82	£82	£82
Y	Inspection of waste connection via a manhole ⁸	per application	1	£116	£116	N/A	£116	N	£116	£116	£116	£116
Infrastructure Charges												
Y	Infrastructure Charge - Water	per property	200	£204	£40,800	N/A	£40,800	N	£204	£40,800	£204	£40,800
Y	Infrastructure Charges - Sewerage ⁹	per property	200	£89	£17,800	N/A	£17,800	N	£89	£17,800	£89	£17,800
Income Offset												
Y	Income Offset - Water	per property	1	-£133	-£26,520	N/A	-£26,520	N	-£133	-£26,520	-£133	-£26,520
Y	Income Offset - Sewerage	per property	1	-£14	-£2,848	N/A	-£2,848	N	-£14	-£2,848	-£14	-£2,848
TOTALS					£223,346		£223,346			£50,042		£37,649

¹ Charges for Alternative Delivery Method are in addition to those charges the SLP/NAV imposes on the customer

² Our charges reflect the average costs whether PE or barrier pipe is used

³ Our Application and Administration fee is combined as one charge

⁴ This is our application and administration fees for each subsequent connection to the first connection above

⁵ This pipework charge is for unmade ground. Our connection charge includes an average charge which covers the 2m in footprint

⁶ Meter installation is included in our service connection rates

⁷ We have included in the example the average cost for our region. A customer will pay the charge applicable to their site location.

⁸ We reserve the right to make the connection ourselves under S107 and different charges would be applicable

⁹ In most large developments, the minimum charge is applicable. However there may be occasional circumstances where higher charges will be applicable.

Scenario 6: Large housing development requiring new mains and communication pipes (excavation and reinstatement completed by Wessex Water)

This worked example provides charges associated with the provision of new water mains and individual connections from them for each of 200 new houses. The worked example includes the associated charges for the 200 property connections to an existing sewer, which are completed by the customer. This worked example assumes that the excavation and reinstatement activities are carried out by Wessex Water, however, should the Developer appoint an SLP or NAV, this worked example assumes these (and other contestable items) would be carried out by the SLP or NAV.

Within construction costs, this includes: Service pipe installation; Boundary box fitting; Meter installation; Excavation; Reinstatement

Technical Specification (Connection) - Pipework (unmade ground):

- Connection to existing main of 180mm diameter PE
- 3m pipe laying (per communication pipe)

Technical Specification (Mains) - Pipework: Total length 1000m, consisting of:

- 180mm diameter PE – 20m pipework in type 3-4 road (leading to point of connection)
 - 180mm diameter PE – 100m pipework in footpath
 - 125mm diameter PE – 480m pipework in unmade ground
 - 90mm diameter PE – 400m pipework in unmade ground
- Design Considerations:
- 250mm diameter existing main, serving 150 existing customers
 - Six commissioning phases
 - Six sample chlorination and connections – Footpath
 - Ten washouts - Unmade Ground
 - Eight valves (1 x 150mm, 5 x 100mm, 2 x 80mm) - Unmade Ground
 - Two trial holes - Unmade Ground

Traffic management assumes the road (Type 3-4) is 50mph, has two lanes and requires a road closure and eight parking pay suspensions. Any additional council charges for permitting should be included. We have included in the example the average cost for our region. A customer will pay the charges applicable to their site and location.

We have further made the assumption that the developer lays new shared drainage with a single existing sewer.

Scenario 6: Large housing development requiring new mains and communication pipe (excavation and reinstatement by Water Company)									Alternative Delivery Method ¹			
Applicable Charge?	Item	Unit	Qty	Rate (£)	Total Charge (£)	Barrier Pipe Uplift /Rate ²	Barrier Pipe Total Charge (£)	Contestable (Y/N)?	Self-Lay Rate (£)	Self-Lay Total Charge (£)	NAV Rate (£)	NAV Total Charge (£)
Pre-Construction Charges - connection												
Y	Application Fee ³	per application	1	£122	£122	N/A	£122	N	£40	£40		
Y	Administration Fee ⁴	per application	199	£33	£6,567	N/A	£6,567	N	£27	£5,373		
N	Design Fee	per application	N/A	N/A		N/A						
Pre-Construction Charges - mains												
Y	Application Fee	per application	1	£95	£95	N/A	£95	N	£95	£95	£95	£95
N	Administration Fee	per application	N/A	N/A		N/A						
Y	Design Fee	per application	1	£460	£460	N/A	£460	Y	£460	£460		
Construction Charges - connection												
Y	Service connection	per connection	200	£923	£184,600	N/A	£184,600	Y				
Y	Pipework ⁵	per metre	200	£265	£53,000	N/A	£53,000	Y				
N	Meter Installation ⁶	per meter	N/A	N/A		N/A						
Construction Charges - mains												
Y	Mains connection	per connection	1	£7,871	£7,871	N/A	£7,871	N	£7,871	£7,871	£7,871	£7,871
Y	Routine in-line mains connections		6	£652	£3,912	N/A	£3,912	Y				
Y	Pipework - unmade	per metre	980	£125	£122,500	N/A	£122,500	Y				
Y	Pipework - footpath	per metre	0	£147	£0	N/A	£0	Y				
Y	Pipework - road	per metre	20	£232	£4,640	N/A	£4,640	Y	£232	£4,640		
Y	Road closure permits ⁷	per road closure	1	£1,149	£1,149	N/A	£1,149	Y	£1,149	£1,149		
Y	Road closure - signage	per road closure	1	£543	£543	N/A	£543	Y	£543	£543		
Y	Designated Parking bay suspension	per road closure	1	£188	£188	N/A	£188	Y	£188	£188		
Other Charges												
Y	Mains Design approval fee	per requisition	1	£253	£253	N/A	£253	N	£253	£253	£253	£253
Y	Mains Pressure testing	per test	6	£519	£3,114	N/A	£3,114	Y				
Y	Mains Chlorination	per phase	6	£370	£2,220	N/A	£2,220	Y				
Y	Mains Sampling and undertaking standard analysis	per sample	6	£187	£1,122	N/A	£1,122	Y				
Y	Waste Connection Admin, App & technical approval fee	per application	1	£82	£82	N/A	£82	N	£82	£82	£82	£82
Y	Inspection of waste connection via existing manhole ⁸	per application	1	£116	£116	N/A	£116	N	£116	£116	£116	£116
Infrastructure Charges												
Y	Infrastructure Charge - Water	per property	200	£204	£40,800	N/A	£40,800	N	£204	£40,800	£204	£40,800
Y	Infrastructure Charges - Sewerage ⁹	per property	200	£89	£17,800	N/A	£17,800	N	£89	£17,800	£89	£17,800
Income Offset												
Y	Income Offset - Water	per property	1	-£133	-£26,520	N/A	-£26,520	N	-£133	-£26,520	-£133	-£26,520
Y	Income Offset - Sewerage	per property	1	-£14	-£2,848	N/A	-£2,848	N	-£14	-£2,848	-£14	-£2,848
TOTALS					£421,786		£421,786			£50,042		£37,649

¹ Charges for Alternative Delivery Method are in addition to those charges the SLP/NAV imposes on the customer

² Our charges reflect the average costs whether PE or barrier pipe is used

³ Our Application and Administration fee is combined as one charge

⁴ This is our application and administration fees for each subsequent connection to the first connection above

⁵ This pipework charge is for unmade ground. Our connection charge includes an average charge which covers the 2m in footpath

⁶ Meter installation is included in our service connection rates

⁷ We have included in the example the average cost for our region. A customer will pay the charge applicable to their site location

⁸ We reserve the right to make the connection ourselves under S107 and different charges would be applicable

⁹ In most large developments, the minimum charge is applicable. However there may be occasional circumstances where higher charges will be applicable.